

## User Manual

Version March 25, 2026

# Thrust Load Meter

## Part of Mechanical Kiln Monitoring System (MKM2)

### 1 INTRODUCTION

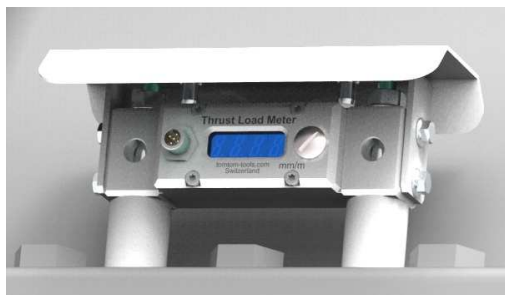

The Thrust Load Meter is part of the new **MKM2** and is used to monitor the axial load on support rollers on rotary kilns or dryers. It helps to easily identify axially high loaded rollers and to counteract timely with adequate adjustment, the so-called roller skewing.

The Thrust Load Meter is an ultra-precise inclinometer which is specially made for the application on large bearing housings as on rotary kilns. The sensor simply needs to be bolted to the bearing housing without opening it. The output signal can be connected to the plant control system for continuous trending of the readings.

#### Measuring Principle

The axial load, the thrust load, coming from the kiln tires needs to be taken by the bearings of the support rollers. The axial load slightly deforms the bearing housing and tilts them to the side. This movement is very small, but big enough to be measured by the Thrust Load Meter. By comparing the different rollers, the one with the higher or lower load can be identified easily, which helps to adjust the skewing properly in a way that the load gets shared among all the support rollers evenly.

Fig. 1.0.1  
Thrust Load Meter  
on bearing  
of support roller

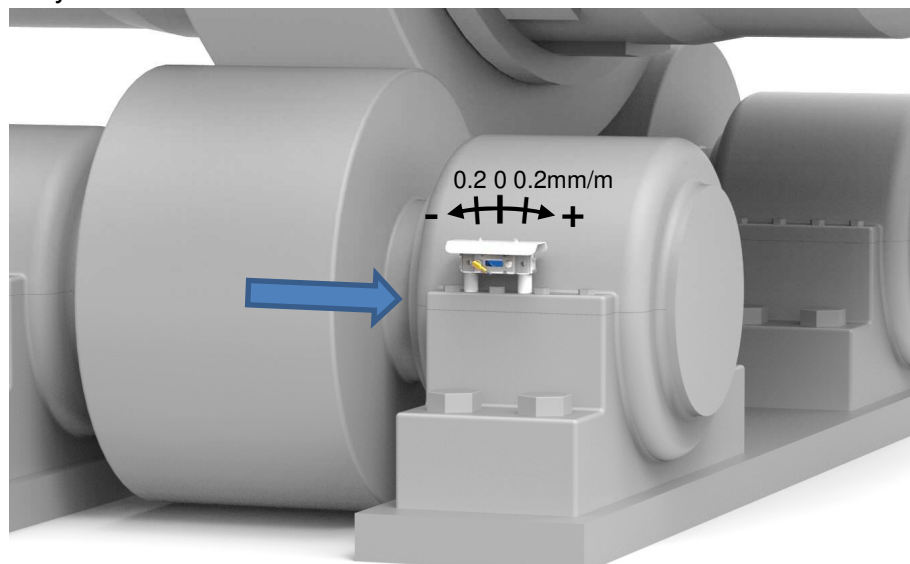

## 2 SAFETY

Rotary kilns and dryers, where this system typically is used, are huge rotating equipment with many pinch points and hot surfaces which can cause serious injuries. Therefore, only specialized and trained personnel shall work close to these machines. For installation, follow strictly the local safety rules given by the respective plant / factory / local authorities and discuss the application with the safety engineer in charge.

The tools provided by TomTom-Tools Ltd. have proven their functionality in various applications; nevertheless TomTom-Tools Ltd. does not take any responsibility for the application on site regarding safety or machine damage. The plant is responsible for the safety, according to the local law, in a way that nobody can be hurt or injured. The application and safety instructions below are guidelines and not exhausted which include the experience from previous installations. They might need to be adapted to the local circumstances and safety requirements.

### Caution:



#### Pinch Points:

Do not put your hands nor any items close or into pinch points.  
(e.g. girth gear / pinion, kiln tires / support rollers, ...)  
Keep safe distance to avoid getting caught by moving parts  
(e.g. switch flags on kiln shell and tires)



#### Magnetic Fields:

The magnets attached to some of the components are strong.  
Be aware of the strong magnetic fields.  
Keep the tool away from people with pace makers or any other sensitive item as credit cards or magnetic data carrier.



#### Hot Surfaces:

The kiln might be very hot, especially the shell of the kiln.  
Do not touch it and keep safe distance.



#### Gloves:

Wear proper gloves to protect your hands from hot and rough surfaces and sharp edges.

**TABLE OF CONTENT**

- 1 INTRODUCTION..... 1
- 2 SAFETY ..... 2
- 3 FEATURES:..... 3
- 4 WHAT BEARING TYPES CAN BE MONITORED? ..... 4
  - 4.1 Only one bearing of each pair is taking axial load..... 4
  - 4.2 Thrust Load Meter is not suitable for moveable support rollers..... 5
  - 4.3 The thrust also can be measured on single housing design ..... 5
- 5 THRUST LOAD METER ON FIXED THRUST ROLLERS ..... 6
  - 5.1 Thrust Rollers with high pedestals..... 6
  - 5.2 Short Thrust Rollers ..... 6
- 6 MOUNTING..... 7
  - 6.1 Location ..... 7
  - 6.2 Bolting..... 7
- 7 WIRING..... 8
  - 7.1 Power Supply ..... 8
  - 7.2 Signal Output ..... 8
- 8 WORKING RANGE ADJUSTMENT ..... 9
- 9 CONFIGURATION .....10
  - 9.1 Linearization of Output Signal .....10
  - 9.2 Change Counting Direction .....10
  - 9.3 Sampling Rate.....10
  - 9.4 Filter.....11
- 10 ZERO POINT ADJUSTMENT.....11
- 11 DRAWINGS .....12
  - 11.1 Thrust Load Meter without heat shield.....12
  - 11.2 Thrust Load Meter with heat shield.....12

**3 FEATURES:**

- Measures the tilting of the bearing housing, due to the side load
- Output value is in mm/m, which is equal to Per mille, parts per thousand [‰]
- Measurement range: -2.9...0...+2.9mm/m
- Value directly visible on the display and provided as analog output signal 4...20mA
- Very low temperature drift
- Adjustable measurement range to fit for bearings with different load behaviors
- Micro screw to adjust the sensor to the inclination of the kiln / dryer
- Strong housing to be suitable for the rough environment

## 4 WHAT BEARING TYPES CAN BE MONITORED?

In general, it can be used on all bearing housings of support rollers, which tilt / deflect slightly due to side loads. On rotary kilns and dryers, that includes most of the bearings, regardless if they are made as slide bearings or bearings with rolling elements. Nevertheless, the following points need to be considered:

### 4.1 Only one bearing of each pair is taking axial load

There exist different designs of support roller assemblies. They use different ways to resist axial forces. But on all of them, only one of the two bearings is taking the axial load. Hence only one Thrust Load Meter per roller is required to monitor the load, but it has to be assured that it gets installed on the loaded bearing.

The following sketches show the most common designs where the location of the Thrust Load Meter is indicated with the following symbol: 

#### a. Axially loaded bearing at uphill side:

Fig. 4.1.1 Thrust Disc is attached to the shaft end



#### b. Axially loaded bearing at downhill side:

Fig. 4.1.2 Thrust Collar is located close to the roller

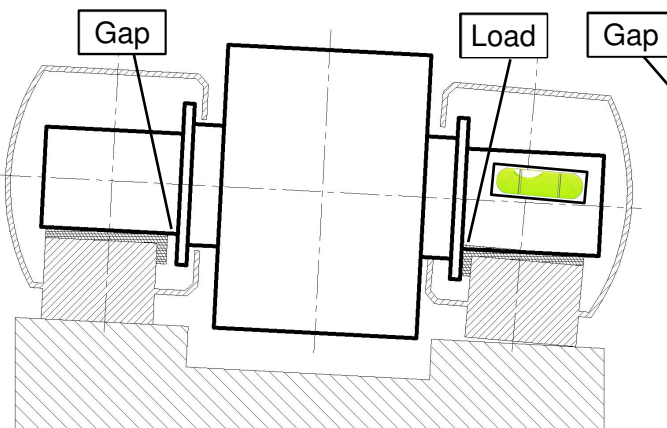
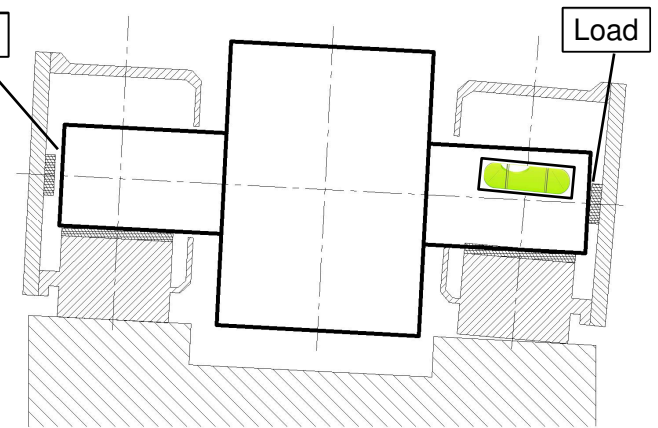

Fig. 4.1.3 Shaft runs against Thrust Disk in housing



**Note:** Whenever possible look for the gap on the thrust shoulder to know which bearing takes axial load.

## 4.2 Thrust Load Meter is not suitable for moveable support rollers

A small number of kilns is equipped with special support roller arrangements to improve the load distribution between the rollers and the tire; these rollers are following the wobbling of the tire. The movement, in this case, is much larger than the tilting of the bearing housing due to side load. That is why the Thrust Load Meter is not suitable on these systems, it would rather show the consequence of the wobble instead of the axial load.

Fig. 4.2.1  
“Semi-Rigid” Support Roller  
(supported on elastomer elements)

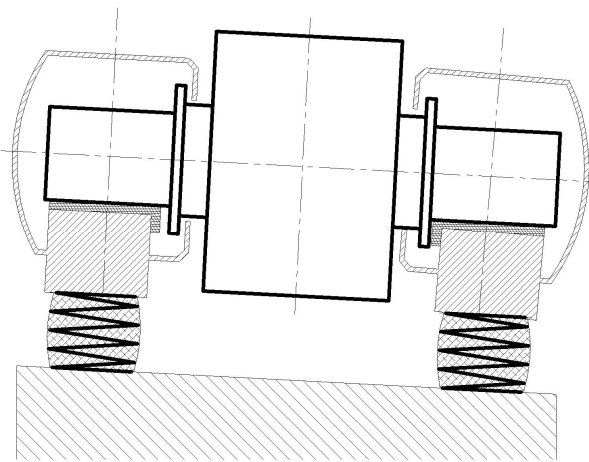
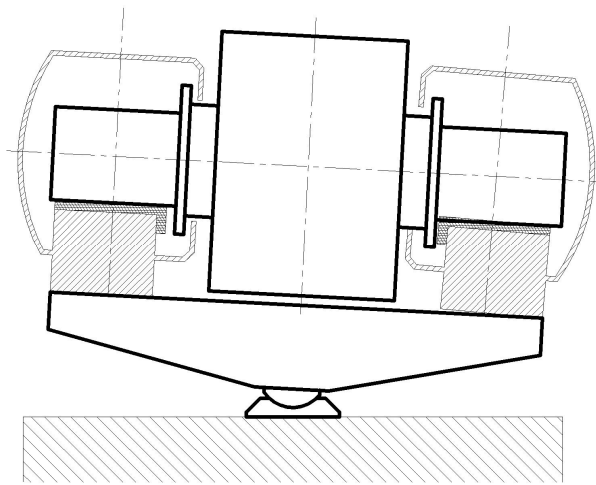

Fig. 4.2.2  
“Self-Aligning” Support Roller  
(supported on a rocking structure)



## 4.3 The thrust also can be measured on single housing design

There exist support roller assemblies, where both bearings are incorporated into one single housing. This design has the advantage that the bores of the bearings are always nicely matching. This arrangement is much stiffer than two independent bearing housings but due to the high sensitivity of the Thrust Load Meter, it is still possible to measure the small deformation caused by the axial load.

Fig. 4.3.1 Single Bearing Housing Design

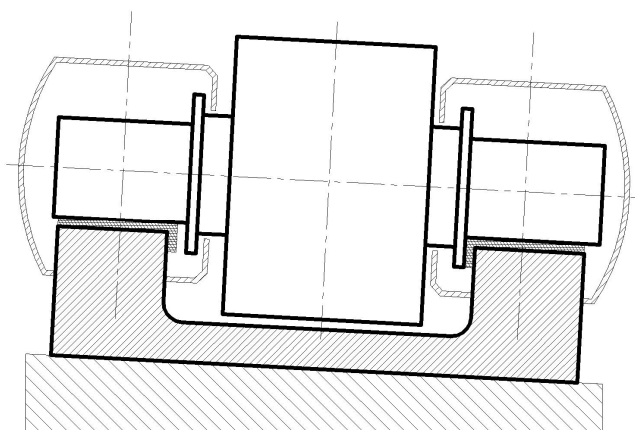

## 5 THRUST LOAD METER ON FIXED THRUST ROLLERS

Modern rotary kilns are equipped with hydraulic thrust rollers where the hydraulic pressure indicates the load which is easily measurable. But older kilns or smaller units sometimes have fixed thrust rollers without the possibility to monitor the load. Here the Thrust Load Meter might be useful too; depending on the stiffness of the roller pedestals.

### 5.1 Thrust Rollers with high pedestals

On thrust rollers which flex slightly due to the forces from the tire, the Thrust Load Meter can be used to monitor the load changes. It has to be attached to the upper part of the pedestal to catch the deflection behavior properly. Usually only the lower thrust roller needs to be monitored, because the upper roller should not get loaded much.

Fig. 5.1.1 Thrust Load Meter on Thrust Roller

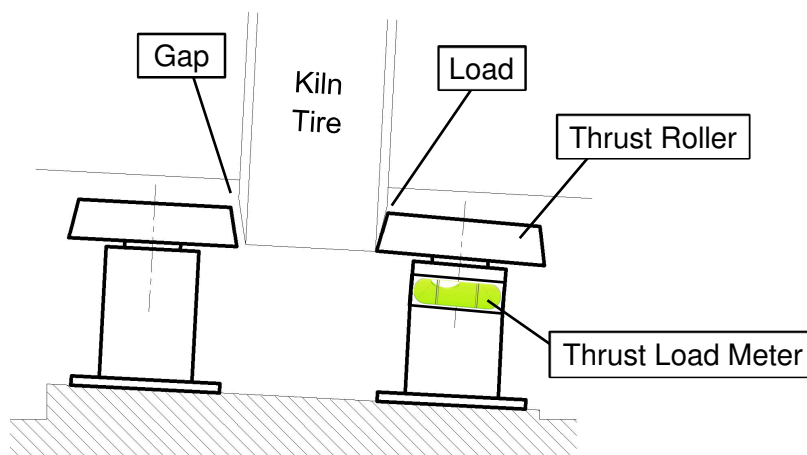

### 5.2 Short Thrust Rollers

Thrust rollers which are mounted close to the foundation will not get tilted sufficiently by the side load, hence the Thrust Load Meter can not be used in this case.

Fig. 5.1.1 Short / Stiff Thrust Roller Arrangement

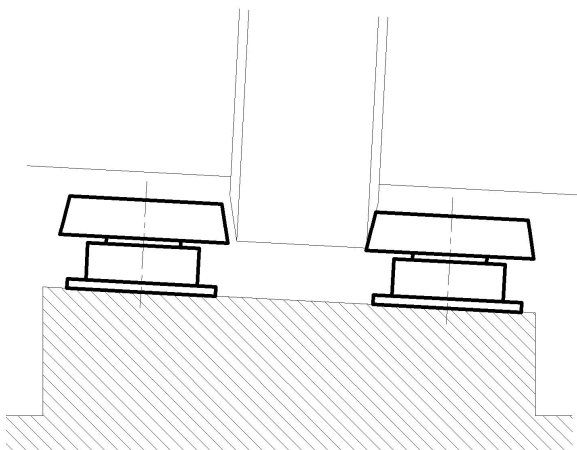

## 6 MOUNTING

### 6.1 Location

The Thrust Load Meter is water and dust tight, and made to be placed close to the kiln. Nevertheless, make sure it is not exposed directly to the radiation from the kiln nor to direct sunlight. The sun would change the temperature which might result in misleading cyclic temperature drift between day and night. Therefore, install the heat shield if needed.

Fig. 6.1.1 Top Mounting

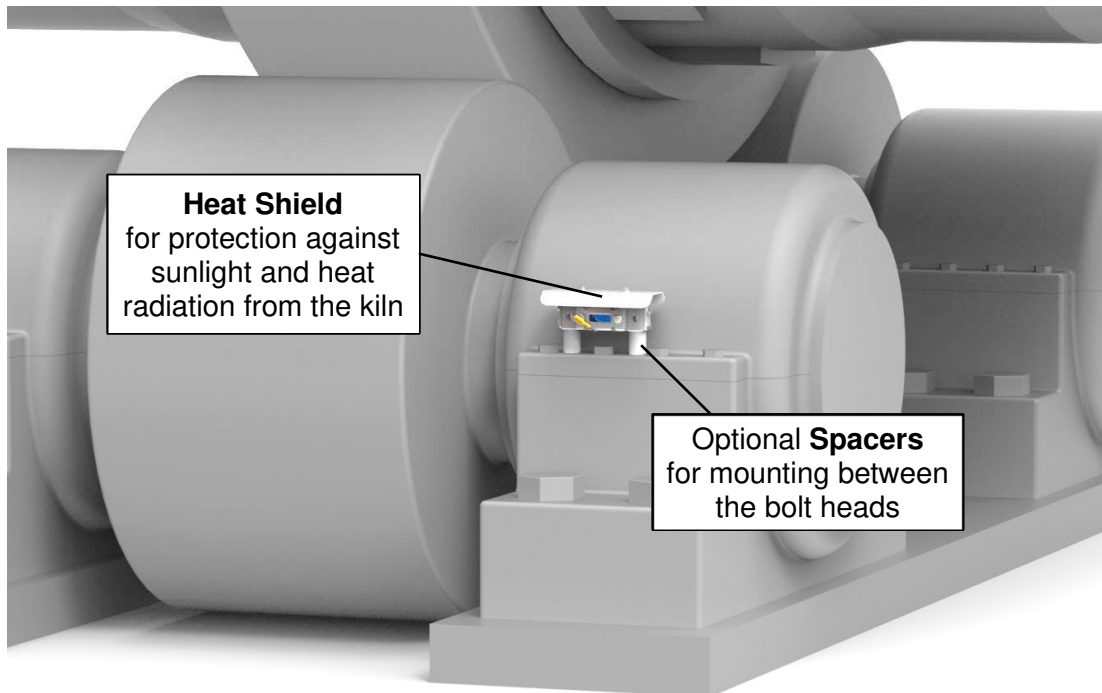

### 6.2 Bolting

The Thrust Load Meter must be connected firmly with the bearing housing, to make sure that it does not change its position over time nor if it gets hit accidentally. Preferable use two M10 bolts, drilled into the bearing housing.

**Note:** For quick installation (e.g. for trials) the Thrust Load Meter can also be attached by strong magnets to the bearing housing.

Fig. 6.2.1  
Front mounting



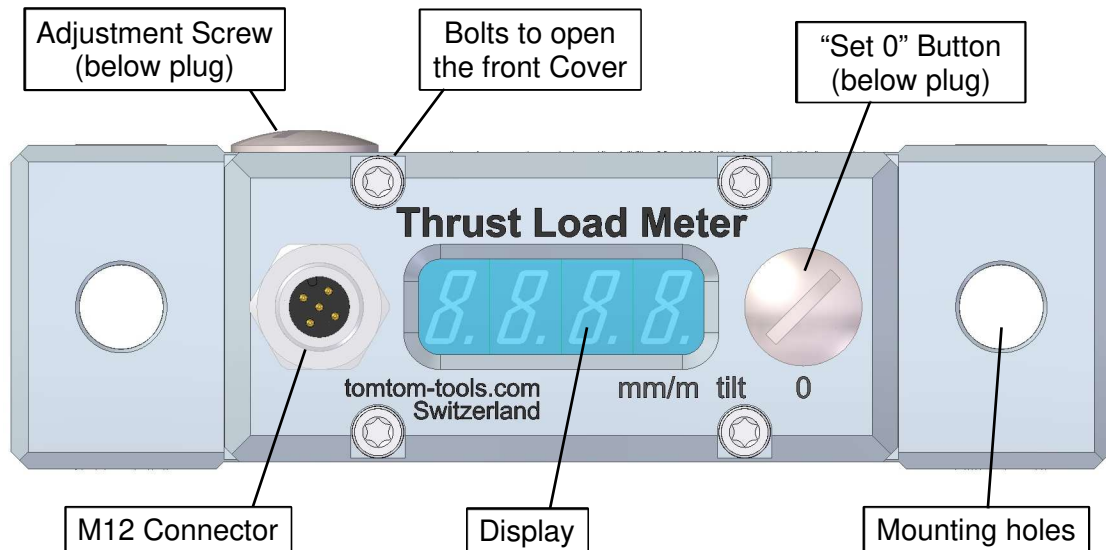

Fig. 6.2.2 Front View

## 7 WIRING

The Thrust Load Meter is equipped with a M12 connector (A-coded, male) in accordance with IEC 61076-2-101.

Pinout:

Pin No.	1	2	3	4 (optional)	5 (optional)
Color	Brown (BN)	White (WH)	Blue (BU)	Black (BK)	Grey (GY)
Assignment	Power (+) 12...30VDC	Analog Output Signal 4...20mA	GND	Error / OK Output Signal 12...30VDC	Shell Pace / Set Zero Input Signal 12...30VDC

Fig. 7.0.1: M12 connector

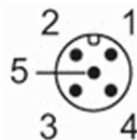

### 7.1 Power Supply

The power consumption of the Thrust Load Meter is less than 0.1A. Hence only one single 24VDC (1A) power source is sufficient for all the Thrust Load Meters on most of the kilns.

### 7.2 Signal Output

The measured inclination value which is shown in the display is provided via wire 2 (white) as an analog output signal (4...20mA).

The range and the direction of counting can be adjusted to the specific load behavior of the bearings on kiln. (see chapter Configuration)

## 8 WORKING RANGE ADJUSTMENT

The high precision inclinometer in the Thrust Load meter has a limited measuring range, which is less than the slope of the kiln; hence it needs to be adjusted after mounting, to work properly. When the sensor is out of range, it is indicated on the display by showing “OUT”.

Fig. 8.0.1 Display when sensor is out of range



Compensating the slope and bringing the sensor into its range, is done with the Adjustment Screw below the plug, in the following way:

1. Open the two plugs to get access to the Adjustment Screw and the “set 0” button
2. Untighten the Lock Nut on the adjustment screw by using the 10mm tubular box spanner
3. Push the “Set 0” button for more than 5 sec  
The display starts blinking, which indicates that it shows the pure sensor value without any offset coming from the signal treatment.
4. Turn the Adjustment Screw with the 3mm Allan key to bring the display to zero (or close to zero)
5. Lock the adjustment screw with the lock nut
6. **Note:** Now would be the time to neutralize the axial load on the bearing to adjust the zero point. This is not so easily and quickly done that is why we skip that step for the moment and come back to the topic later in chapter 10 “Zero Point Adjustment”. (The assistance of a kiln specialist might be required for Point 6)
7. Push the “Set 0” button for 1 sec, the display will stop blinking and the possibly remaining small offset will be set to zero. The Thrust Load Meter is working now properly and will show the axial load changes, but the value is not representing the absolute load, because we skipped point 6 for the moment
8. Close both plugs to avoid dust and water entering the housing

Fig. 8.0.2 Front view with open plug

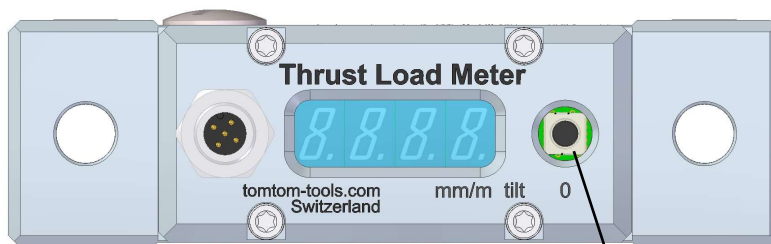

“Set 0” Button

Fig. 8.0.3 Top view with open plug

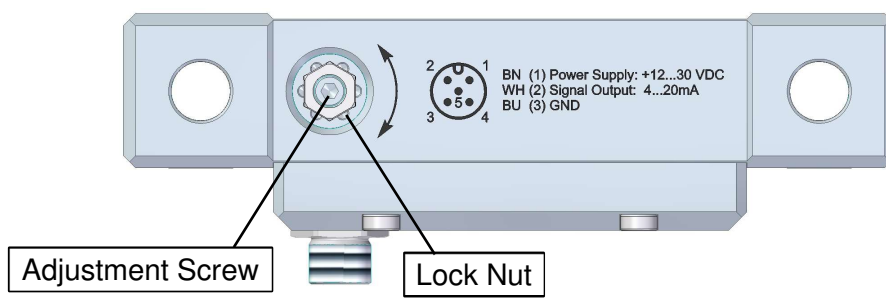

Allan Key (3mm)

Tubular Box Spanner (10mm)

## 9 CONFIGURATION

To optimize the way of working of the Thrust Load Meter, some parameter can be configured. For that the front cover needs to be opened with a Torx screw driver (TX15).

**Attention:** Open the cover carefully to avoid damaging the fine ribbon cable going from the circuit board to the inclination sensor.

Fig. 9.0.1:

Back side of circuit board

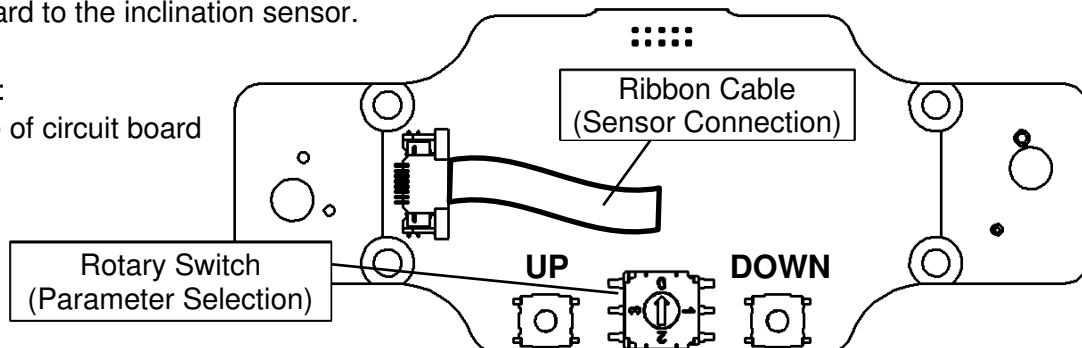

Normal operation: rotary switch position "0"



### 9.1 Linearization of Output Signal

Some bearing arrangements are quite flexible, other stiffer; hence they behave differently under load. To get the output signal (4...20mA) covering the range of the expected deflection, the linearization can be adjusted accordingly in the following way:

1. Turn the rotary switch to position 1
2. Adjust the linearization by pushing the UP or DOWN button (0.1...0.4 mm/m/mA)

Setting [mm/m/mA]	0.1	0.2	0.3	0.4 (default)
Measurement Range [mm/m]	-0.8...+0.8	-1.6...+1.6	-2.4...+2.4	-3.2...+3.2
Output Signal [mA]	4...20	4...20	4...20	4...20

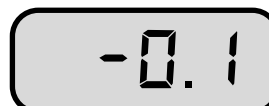

### 9.2 Change Counting Direction

When Thrust Load Meters are installed on both sides of the kiln, the orientation is mirrored. To get from both side of the kiln the output signal in the same manner, the counting direction can be inverted by entering negative Linearization values.

Setting [mm/m/mA]	-0.1	-0.2	-0.3	-0.4
Measurement Range [mm/m]	+0.8...-0.8	+1.6...-1.6	+2.4...-2.4	+3.2...-3.2
Output Signal [mA]	4...20	4...20	4...20	4...20

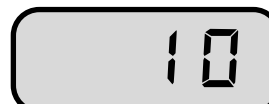

### 9.3 Sampling Rate

The sampling rate of the inclination sensor can be changed as follows:

1. Turn the rotary switch to position 2
2. Adjust the sampling rate by pushing the UP or DOWN button (2, 5, 10, 20 Hz)

As the kilns are slow rotating machines, the **default sampling rate of 10Hz** should be sufficient, hence there is usually no need to change the sampling rate.

## 9.4 Filter

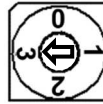

The Thrust Load Meter is equipped with a filter function to smoothen the output signal. Signal smoothing is usually required, because disturbances are overlaying the measurement.

Disturbances can be for example:

- Wobbling of kiln tire
- Variation in friction factor due to oil on the roller and tire surfaces
- Crank in the kiln shell, which changes the load on the support rollers

The signal smoothing is based on a floating average filter. It can be adjusted as follows:

1. Turn the rotary switch to position 3
2. Adjust the length / duration (sec.) of the floating average widow by pushing the UP or DOWN button (1...120sec), The example above shows 60sec. (default: 1sec.)
3. When the filter value is set to “0”, the value is updated with the sampling rate of the sensor as described in chapter 9.3
4. When the filter value is set to “PACE” (1 step below 0) the floating average window will adjust automatically to the rotation speed of the kiln. For that mode, the shell pace signal needs to be fed to pin 5 (grey wire). The shell pace signal is one pulse (24VDC) per kiln turn, typically coming from an inductive sensor. For more information about the pace sensor, please contact TomTom-Tools.

## 10 ZERO POINT ADJUSTMENT

To get absolute and comparable values, the zero point needs to be defined. That means the display has to show zero when the axial load is zero. To eliminate temporarily the axial load on the support rollers, while the kiln is rotating, the following ways are usually used:

- a. **Apply soap to the roller surface:**  
Hold a soap block against the roller surface; it reduces drastically the friction factor between the tire and the roller, hence the axial load is significantly reduced. This method is not very precise but very simple and quick. It is usually meant to check if the Thrust Load Meters are working.
- b. **Neutralize the roller skewing (recommended):**  
Move the support roller in a way that the skewing changes and the normally loaded bearing has no axial load anymore until a gap opens on the thrust collar. Move for this exercise only the bearing housing where no Thrust Load Meter is installed, to avoid any influence to the measurement due to the movements.
- c. **Use hydraulic device to unload the thrust shoulder**  
For some bearing types, a hydraulic device is available, provided by the kiln manufacturer, to unload the thrust shoulder temporarily. It can be used for this calibration purpose as well.

When you have reached the neutral roller position, or even slight negative force, perform the following steps:

1. Open the plug on the Thrust Load Meter to get access to the “Set 0” button
2. Push it for >5 sec, the display is blinking, double check if you are still close to zero
3. Push the “Set 0” button (short) and the display is set to zero
4. If a roller was moved, move the bearing back to get some skewing
5. Make sure that on all the support rollers similar skewing is applied and that the pressure of the hydraulic thrust roller stays in normal operating range

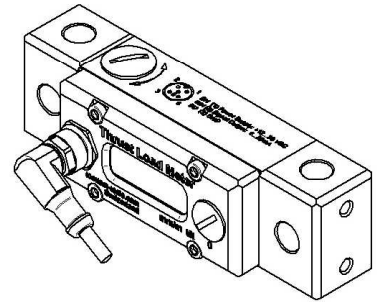
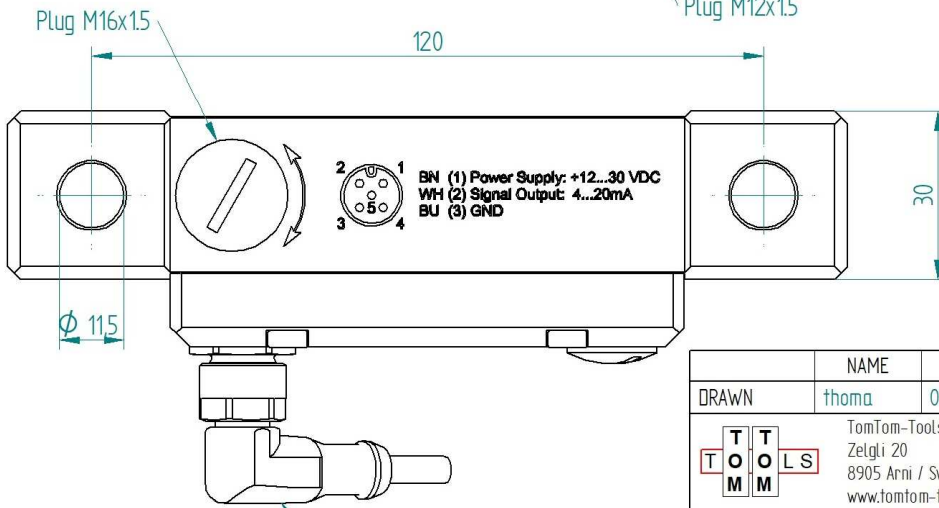
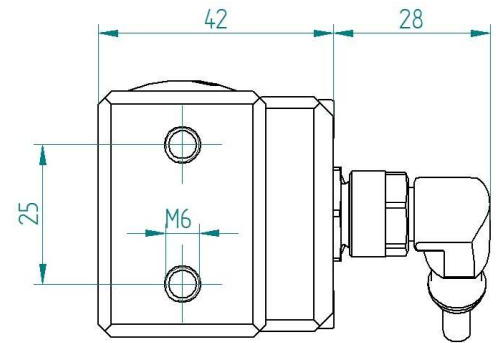
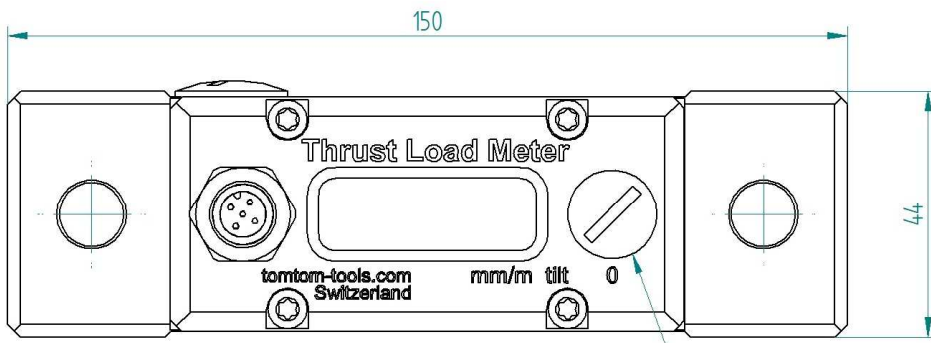

Housing Material:  
Aluminium (anodized)

Angular female connector  
M12x1 (4 pins, A-coded)

	NAME	DATE	Thrust Load Meter	
DRAWN	thoma	03/12/21		
	TomTom-Tools GmbH Zelgli 20 8905 Arni / Switzerland www.tomtom-tools.com		TITLE without heat shield	
	UNLESS OTHERWISE SPECIFIED DIMENSIONS ARE IN MILLIMETERS DIMENSIONS ± 0.1 mm ANGLES ± 0.1° TYPICAL EDGE CHAMFER 0.3x45°	SIZE A4	DWG NO TLM.01.200	REV
			FILE NAME: TLM.01.200 Thrust Load Meter.dft	
			SCALE:	WEIGHT:
			SHEET 1 OF 1	

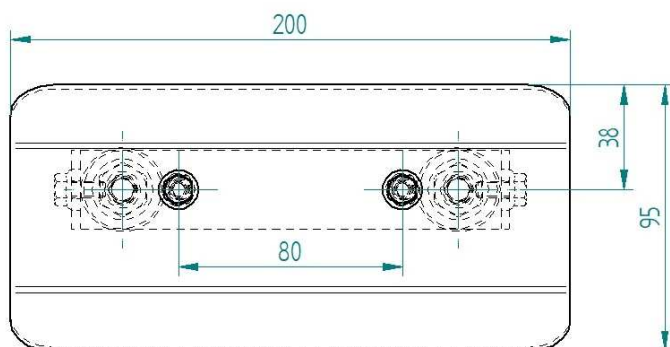
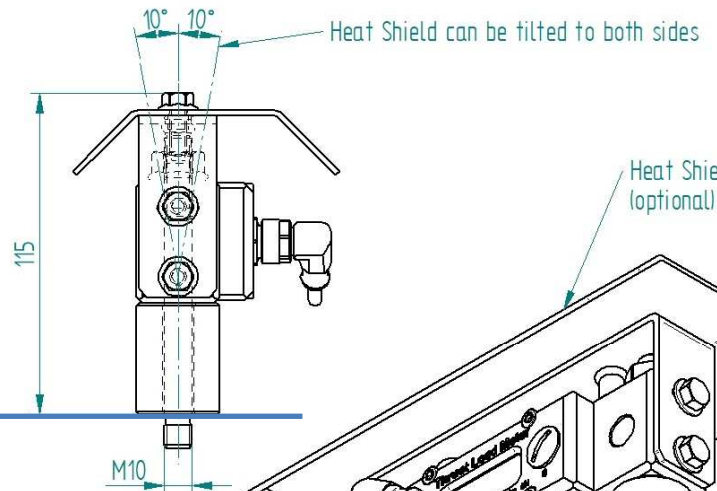
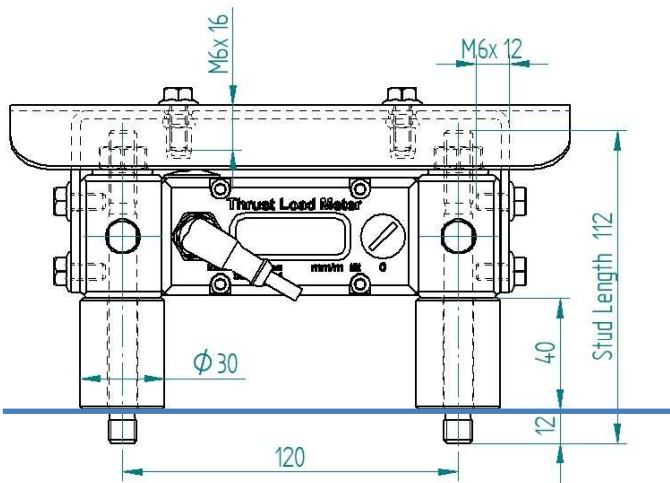

Spacer Bush  
(optional)

	NAME	DATE	Thrust Load Meter	
DRAWN	thoma	03/12/21		
	TomTom-Tools GmbH Zelgli 20 8905 Arni / Switzerland www.tomtom-tools.com		TITLE Heat Shield and Mounting	
	UNLESS OTHERWISE SPECIFIED DIMENSIONS ARE IN MILLIMETERS DIMENSIONS ± 0.1 mm ANGLES ± 0.1° TYPICAL EDGE CHAMFER 0.3x45°	SIZE A4	DWG NO TLM.01.000	REV
			FILE NAME: TLM.01.000 Thrust Load Meter.dft	
			SCALE:	WEIGHT:
			SHEET 1 OF 1	