

User Manual

Version March 25, 2026

Run-Out Monitor

1 INTRODUCTION

Fig. 1.0.1 Gear Run-Out Monitor Controller



The Run-Out Monitor is designed for two main purposes, to monitor the run-out of ring gears and the run-out of running tracks for slide bearings, but it can be used for many other applications as well. The system measures and warns about dangerous run-out in rotary kilns, tube mills, rotary dryers and other machines.

The alignment of the girth gear and the bearing surfaces are affected by changes in the tubular kiln or ball mill shell. Uneven temperatures or looseness can result in distortions and affect the girth gear and the bearing surfaces. Misalignment or run-out of the gear affects the mesh with the pinion, which can cause vibration and damage to the drive train. Run-out on bearing surfaces (tires, trunnions) is dangerous for the bearings. It can be caused by thermal effects too, but also by cracks. It is important to detect issues in an early state to avoid major damage and long down time.

The Run-Out Monitor is designed to be installed permanently and provides the values as two independent signals (4...20mA) to the control system of the factory.

Measuring Principle

Two inductive distance sensors measure synchronously the distance to the tooth tips of the girth gear or another surface to be monitored. This arrangement of measuring the run-out in radial direction brings the great advantage, that also the magnitude of the axial run-out can be detected. The controller, analyzes the changes in the sensor signal in the following way:

- a) If there would be no variation in the sensor signals → that means, there is no run-out
- b) When both sensors see the same variation → there is radial run-out
- c) If the distances differ from one sensor to the other → axial run-out

Note: Usually, are combinations present, but they are analyzed in the same way.

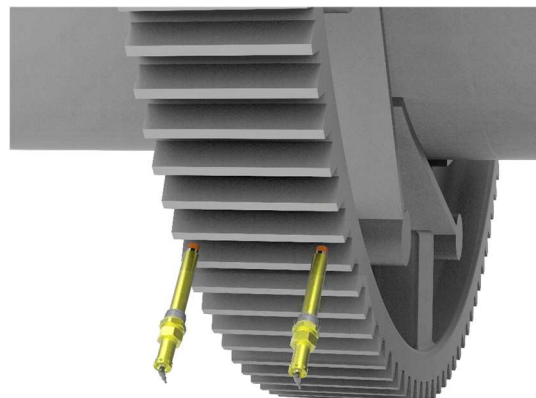
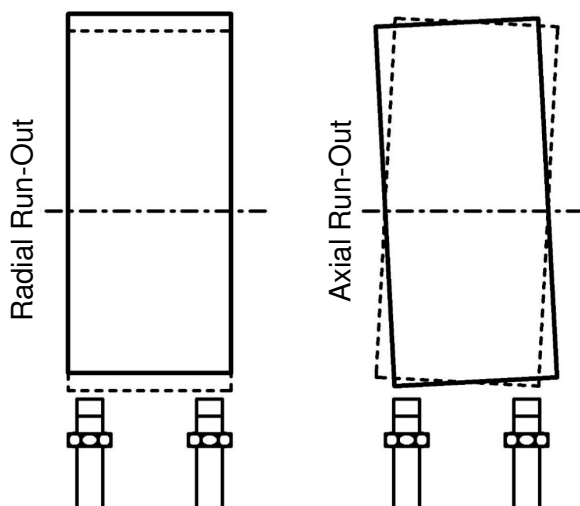

Example: Monitoring of Girth Gear

2 SAFETY

Rotary kilns, dryers and tube mills, where this system typically is used, are huge rotating equipment with many pinch points and hot surfaces which can cause serious injuries. Therefore, only specialized and trained personnel shall work close to these machines. For installation, follow strictly the local safety rules given by the respective plant / factory / local authorities and discuss the application with the safety engineer in charge.

The tools provided by TomTom-Tools Ltd. have proven their functionality in various applications; nevertheless TomTom-Tools Ltd. does not take any responsibility for the application on site regarding safety or machine damage. The plant is responsible for the safety, according to the local law, in a way that nobody can be hurt or injured. The application and safety instructions below are guidelines and not exhausted which include the experience from previous installations. They might need to be adapted to the local circumstances and safety requirements.

Caution:



Pinch Points:

Do not put your hands nor any items close or into pinch points.

(e.g. girth gear / pinion, kiln tires / support rollers, ...)

Keep safe distance to avoid getting caught by moving parts

(e.g. switch flags on kiln shell and tires)



Install the sensors only when the equipment is stopped. Place the Reference Sensor out of reach, out of normal access



Hot Surfaces:

The kiln might be very hot, especially the shell of the kiln.

Do not touch it and keep safe distance.



Fire:

Take care about the risk of fire during the installation of the sensors.

Special precautionary measures are required while performing hot work close to inflammable materials e.g. lubricants



Gloves:

Wear proper gloves to protect your hands from hot and rough surfaces and sharp edges.

TABLE OF CONTENT

- 1 INTRODUCTION..... 1
- 2 SAFETY 2
- 3 Features:..... 3
- 4 TYPICAL SETUP 4
 - 4.1 Run-Out Measurement of Girth Gears..... 4
 - 4.2 Run-Out Monitoring of Continuous Surfaces 5
 - 4.3 Sensor Size and Measuring Range 6
- 5 INSTALLATION..... 7
 - 5.1 Run-Out Sensors on Girth gears 7
 - 5.2 Run-Out Sensors on Slide Shoe Track of Ball Mills 8
 - 5.3 Run-Out Sensors on Kiln Tires..... 8
 - 5.4 Run-Out Sensors on Trunnions of Ball Mills 9
 - 5.5 Reference Sensor 9
 - 5.6 Run-Out Monitor Controller 10
- 6 WIRING..... 11
 - 6.1 Wiring for Gear Run-Out Monitoring 12
 - 6.2 Wiring for Run-Out Monitoring of continuous surfaces..... 12
 - 6.3 Power Supply 13
 - 6.4 Rotation Signal..... 13
 - 6.5 Run-Out Measurement..... 13
 - 6.6 Run-Out Sensor Overview..... 14
 - 6.7 Signal Output 15
- 7 CONFIGURATION 17
 - 7.1 Number of Teeth 17
 - 7.2 Diameter to Sensor Distance Ratio 18
 - 7.3 Sensor Linearization..... 18
- 8 DRAWINGS 19
 - 8.1 Run-Out Monitor..... 19
 - 8.2 Run-Out Sensor 30mm 20
 - 8.3 Run-Out Sensor 18mm 20

3 Features:

- Output 1: Radial Run-Out value in mm
(the +/- deviation from the perfect concentric circle)
- Output 2: Axial Run-Out value in mm
(the +/- deviation from the perfectly straight running gear)
- The sensor arrangement allows axial movement of the gear without affecting the runout values
- The measurement is not affected by lubricants nor dust

4 TYPICAL SETUP

4.1 Run-Out Measurement of Girth Gears

Two inductive distance sensors are placed through the housing of the girth gear and measure continuously the distance to the tooth tips. The amount the distance varies represents the run-out. The analog sensor signals (4...20mA) are provided to the controller.

Fig. 4.0.1 Typical setup on girth gear

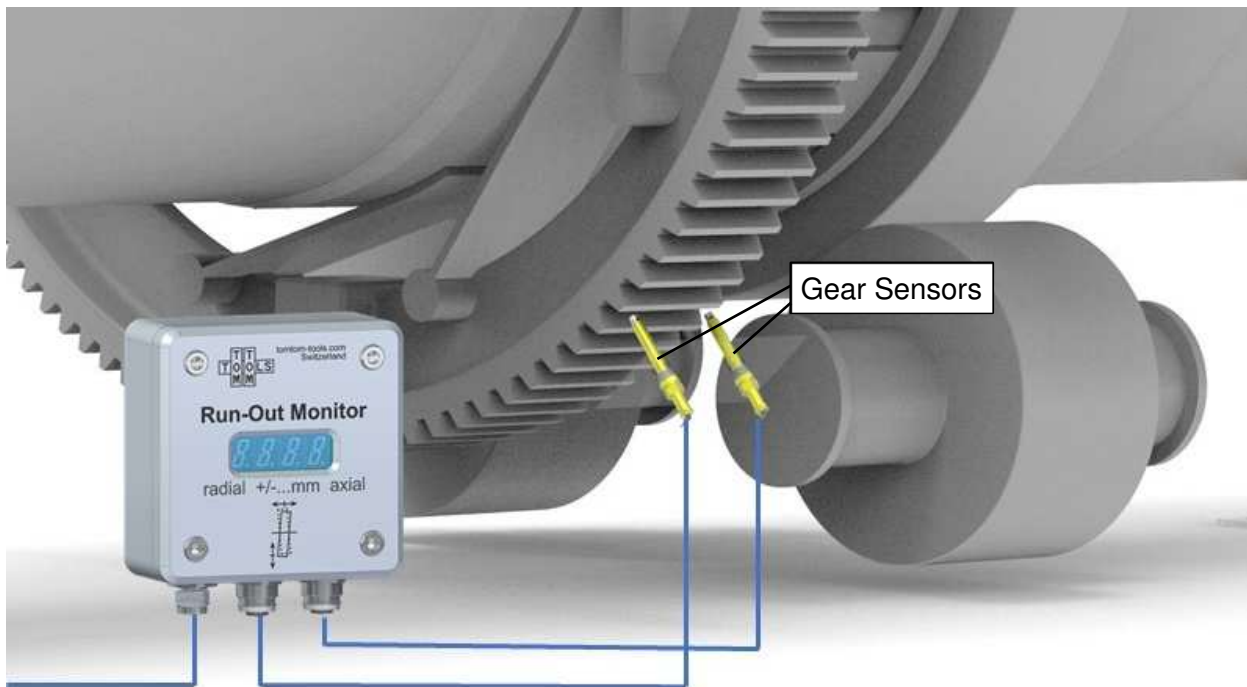
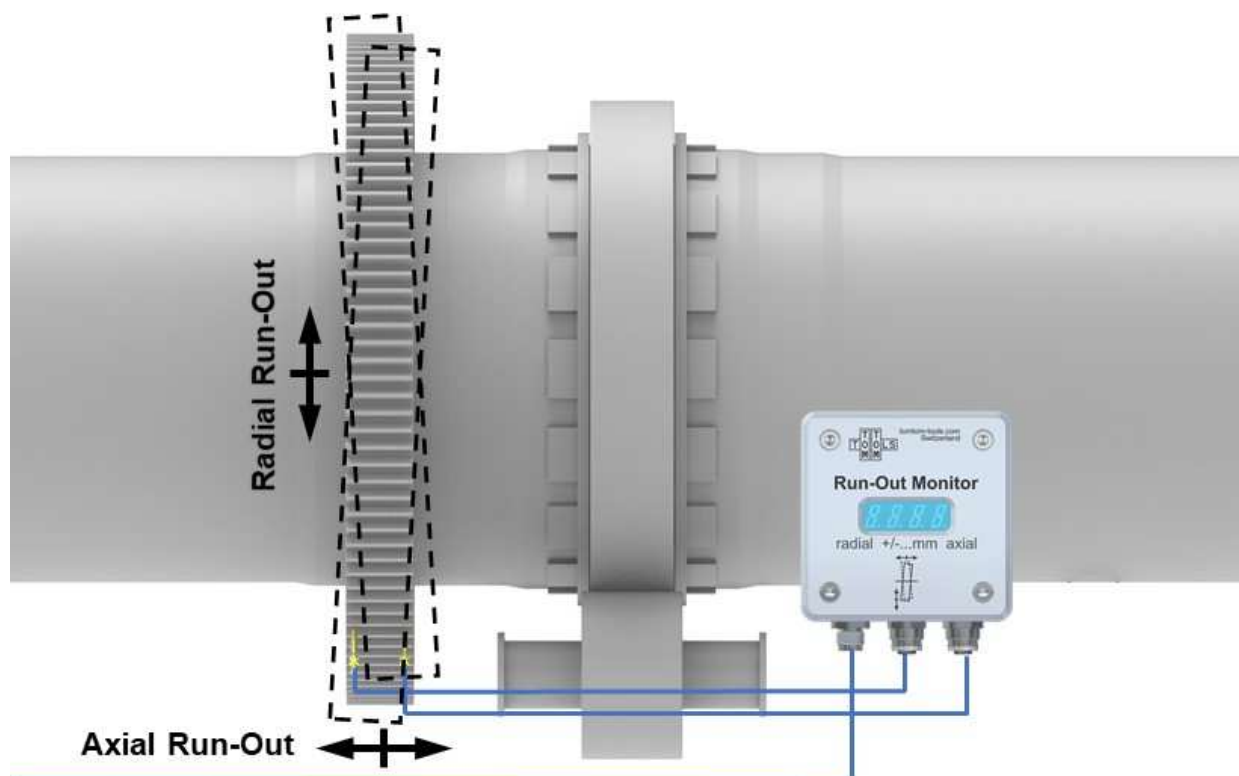
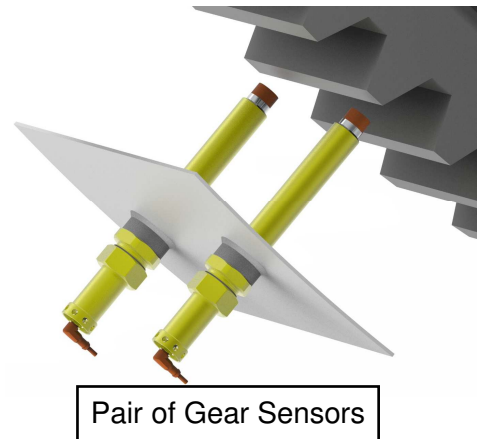

Fig. 4.0.2 The two dimensions of run-out measurement (radial and axial)



Using two sensors measuring the gear makes it possible to get not only the radial run-out but also the axial run-out. It is done by comparing the small difference between the two sensor signals which is caused by the axial component of the run-out. When a gear would run perfectly straight but only with run-out in radial direction, both signals would be perfectly identical, hence the difference is representing the wobble. The controller is able to calculate realistic values by signal comparison and by knowing the ratio between sensor distance and gear diameter.



4.2 Run-Out Monitoring of Continuous Surfaces

The Run-Out Monitor can also be used to monitor surfaces without teeth as shown in the following examples of ball mills, also called tube mills.

The two inductive distance sensors are measuring the running surfaces of the slide shoe bearings. Deviations in the running surface can be dangerous for the slide shoes and are typically caused by uneven temperature distributions in the mill shell.

Fig.4.2.1 Ball mill with slide shoe bearings

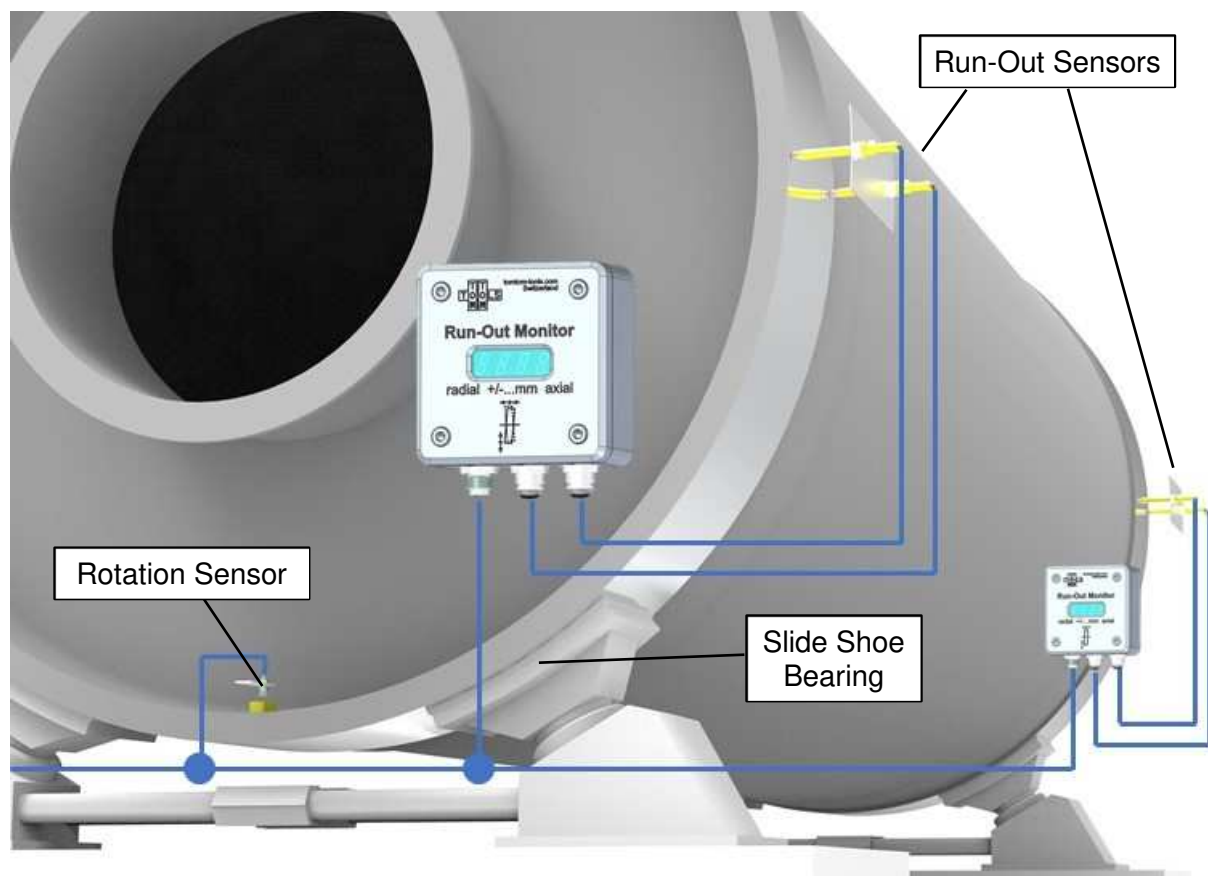

As the mill is sitting on the slide shoes in a typical angle of 30°, not much radial run-out is expected. But by installing the sensors at the 3 or 9 o'clock position, significant radial run-out might be measured. The radial run-out is caused by roundness deviation in the running surface. These deviations will “shake” the mill from one side to the other. The magnitude will be shown by the Run-Out monitor.

The next example shows a ball mill with trunnion bearings where the two inductive sensors are placed on top, inside the bearing housing, to measure the run-out.

Fig.4.2.2 Ball mill with trunnion bearings

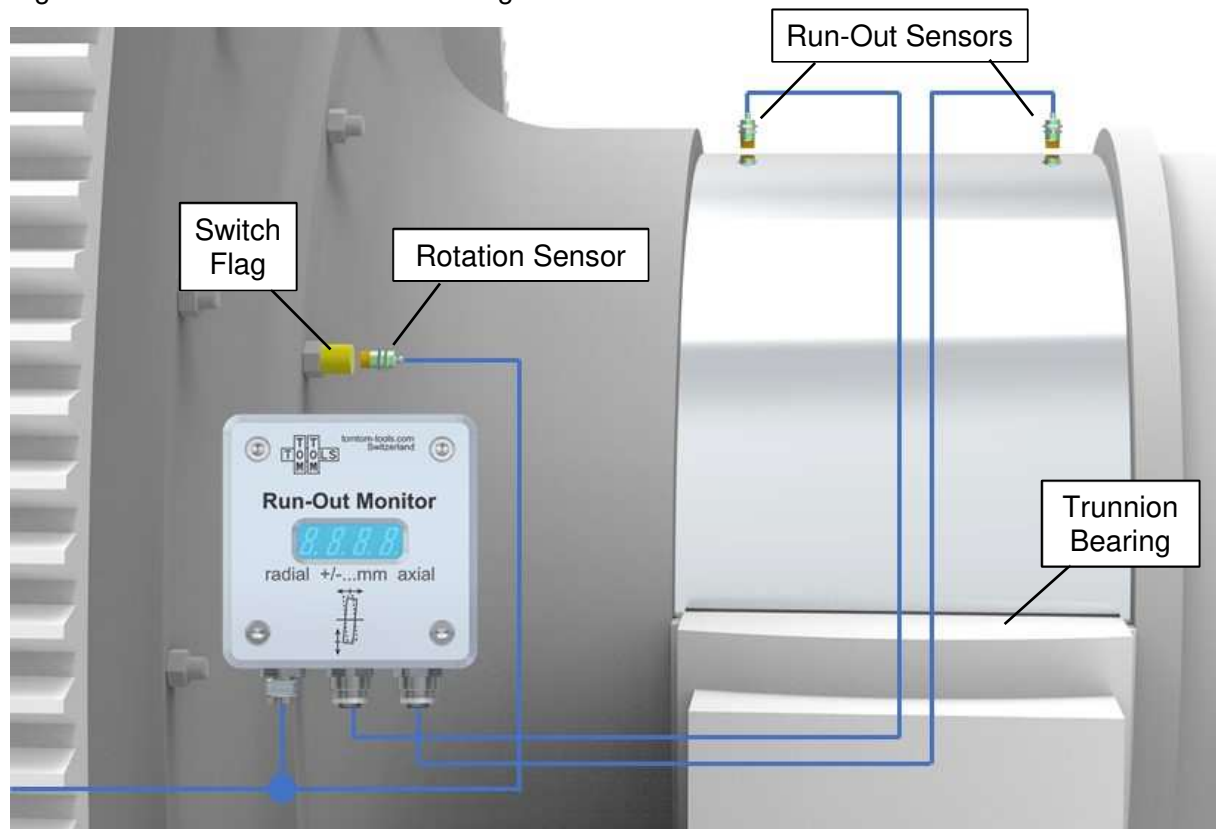

Note:

The algorithm to calculate the run-out needs to know when the girth gear or the monitored surface has made a full turn. On a girth gear this is done by counting the number of teeth. But on surfaces without teeth a Rotation Sensor is needed, which provides one pulse per turn.

4.3 Sensor Size and Measuring Range

The Run-Out sensors and their measuring range must be selected according to the maximal expected run-out. To measure correctly, the distance must remain within the range of the sensor. On rotary kilns, higher run-out is expected than on ball mills, hence larger sensors with higher ranges are required than on ball mills. On mills, small deviations already need to be detected, hence small sensors with high accuracy, but small ranges are required. The following table shows the typical sensor selection:

Application	Type:	Thread Size	Range	Linearization
Kiln Girth Gear	II6913	M30x1.5	1...15mm	0.875mm/mA
Kiln Tire	II6913	M30x1.5	1...15mm	0.875mm/mA
Mill Girth Gear	IG6083	M18x1	0.8...8mm	0.45mm/mA
Mill Slide Shoe Track	IG6083	M18x1	0.8...8mm	0.45mm/mA
Mill Trunnion	IF6030	M12x1	0.4...4mm	0.225mm/mA

All sensors have an analog output of 4...20mA

5 INSTALLATION

The installation and commissioning of the system is not very complicated, but some tailor-made brackets might be required, which are usually made by technician of the cement factory. All sensors come with readymade connection cables.

The Run-Out Sensors are always installed as a pair. The Rotation Sensor is needed, when a surface without teeth is monitored.

5.1 Run-Out Sensors on Girth gears

The Gear Sensors are inductive distance sensors with an analog output, which measure their distance to the tooth tips. They provide a 4...20mA signal that gets a low point each time a tooth is passing through the sensor ranges. The controller is processing these lowest points to calculate the run-out. Here some important tips for the installation:

- a) Look for a good location to place the Gear Sensors. They should be easy and save accessible, but out of the way of walkways and not interfere with regular maintenance activities.
- b) Make sure, that the sensors are installed close to both sides of the tooth width to have them as far as possible apart from each other. But take the axial travel of the girth gear into account and assure that the girth gear is not moving out of the sensor ranges.
- c) When the place is identified, clean the area and remove the lubricant to avoid any risk of fire.
- d) Cut two holes into the housing of the girth gear and weld two threaded socket (G 1½") onto the holes.
- e) Clean and re-paint the areas to avoid corrosion
- f) Mount the Sensor Fittings into the threaded sockets. Apply anti seize grease.
- g) Insert the Gear Sensors into the fittings and adjust the distance to the tooth tip to be approximately in the middle of the measuring range
- h) Lock the position by tightening the nut on the fitting
- i) To assure that the sensors cannot move into the gear at any circumstance, add the lock rings in front of the nuts
- j) Connect the Gear Sensors to the Run-Out Monitor (Connector B and C)

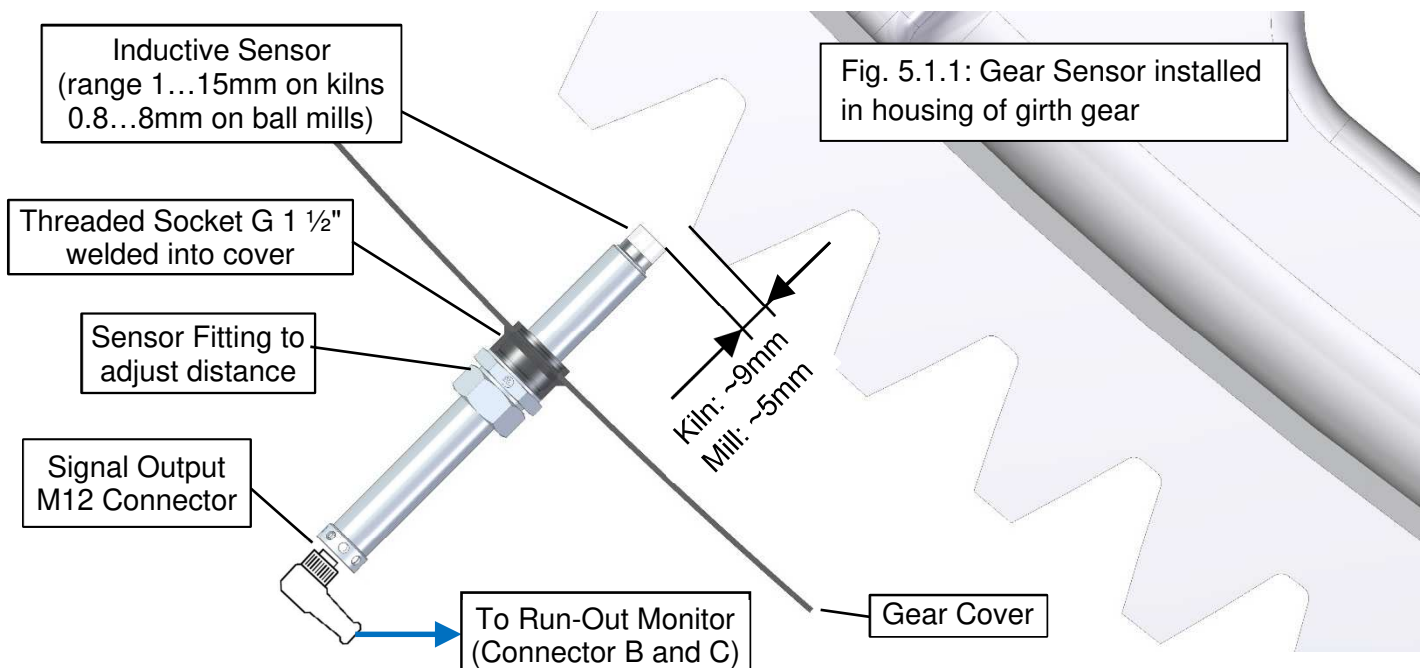

5.2 Run-Out Sensors on Slide Shoe Track of Ball Mills

The Run-Out Sensors and the installation are very similar to the gear measurement described before. These sensors measure their distances to the running surface for the slide shoes.

Here some important points for the installation:

- a) Install the Run-Out Sensors at the 3 or 9 o'clock position into the housing of the ball mill
- b) Make sure, that the sensors are installed close to both sides of the track width to have them as far as possible apart from each other.
- c) When the place is identified, clean the area and remove the lubricant to avoid any risk of fire.
- d) Cut two holes into the housing and weld two threaded sockets (G 3/4") onto the holes.
- e) Clean and re-paint the areas to avoid corrosion
- f) Mount the Sensor Fittings into the threaded sockets. Use Teflon tape to avoid oil leakage.
- g) Apply anti seize grease to the sensor fitting and insert the Run-Out Sensors
- h) Adjust the required distance (~5mm) to the running surface.
- i) Lock the position by tightening the nut on the fitting
- j) Connect the Run-Out sensors to the Run-Out Monitor (Connector B and C)

Fig. 5.2.1 Run-Out Sensor measuring the running surface for slide shoe bearings

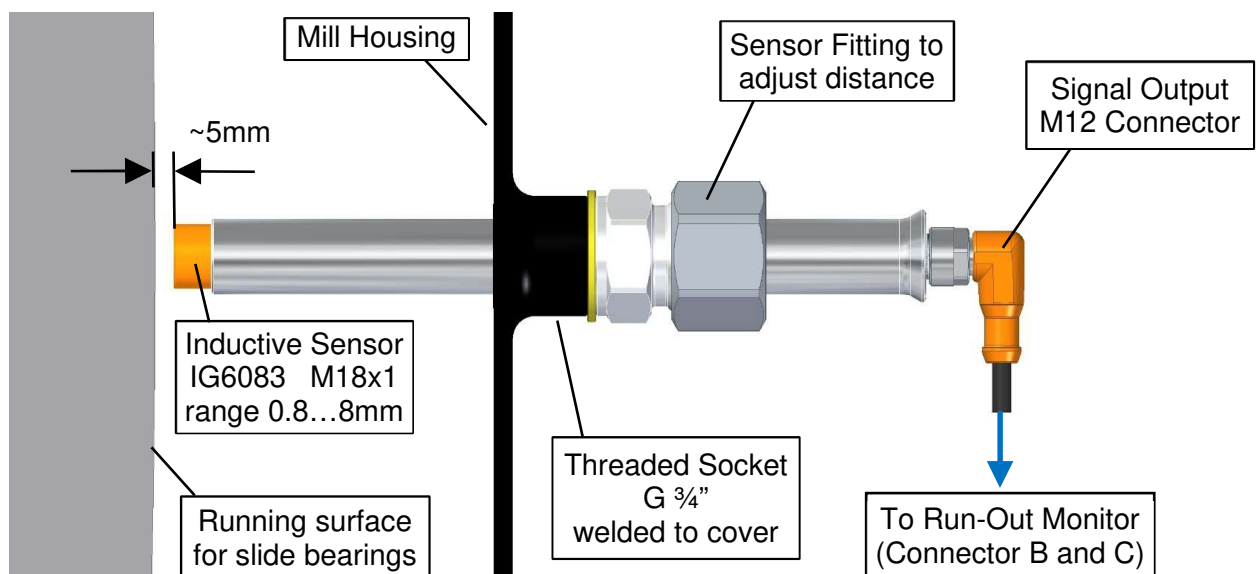

5.3 Run-Out Sensors on Kiln Tires

The axial run-out, also called wobble, of kiln tires can be measured with the Run-Out Monitor as well. For this application, the sensors are installed below the tires at the 6 o'clock position.

Note: The temperature resistance of the sensors might not be sufficient to withstand the temperature under the tire, hence forced air cooling might be required

5.4 Run-Out Sensors on Trunnions of Ball Mills

The sensors to measure the run-out of trunnions are typically installed inside the bearing housing, as shown in the picture below.

Here some important points for the installation:

- k) Install the sensors from the top, at the 12 o'clock position
- k) Place the sensors close to both sides of the track width to have them as far as possible apart from each other.
- l) When the place is identified, manufacture brackets to hold the sensors firmly and save. Make sure the brackets are robust and will not break due to vibration
- m) Mount the sensors on the brackets
Apply adhesive (e.g. Loctite) to the bolts and nuts to avoid any looseness
- n) Adjust the required distance (2...3mm) to the running surface.
- o) Connect the Run-Out sensors to the Run-Out Monitor (Connector B and C)
- p) Use Through Wall connectors, if needed, to pass the cables from the inside to the outside of the bearing housing.
- q) Secure the cables, make sure they will not get in contact with rotating parts

Fig. 5.3.1 Run-Out Sensor measuring the bearing surface of a mill trunnion

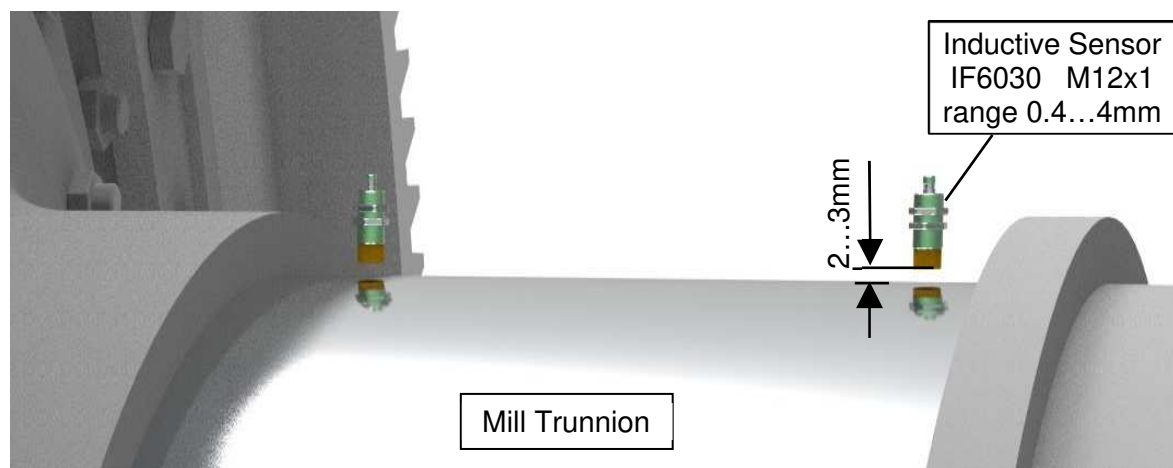

5.5 Reference Sensor

The Reference Sensor is an inductive proximity sensor. It is used when the run-out of continuous surfaces is measured (no teeth). The reference sensor needs to provide one pulse per kiln or mill turn. This is achieved by attaching (by magnets or welding) a steel piece to the kiln or mill shell, which acts as a switch flag. For safety reason, the switch flag needs to have a strong hold that it cannot fall off.

- a) Look for a good location to place the sensor and make sure it is out of the way where regular access for maintenance is need.
- b) Do not expose the Reference Sensor unnecessarily to high temperature. In case a heat-resistant sensor is required, please mention it before ordering
- c) Manufacture and install a strong and rigid bracket for the sensor
- d) Make sure the switch flag and the sensor are matching even when there is some axial movement e.g. due to thermal expansion.
- e) Adjust the distance to the Switch Flag to be within the sensor range and make sure that the sensor will not touch the switch flag.
- f) Connect the sensor via Y-Splitter to the power cable as shown in Fig. 6.2.1

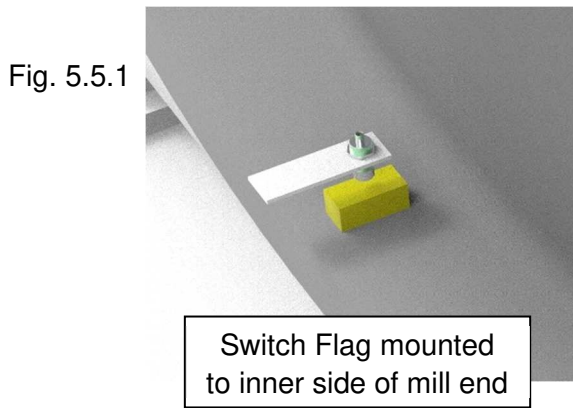

Switch Flag mounted to inner side of mill end

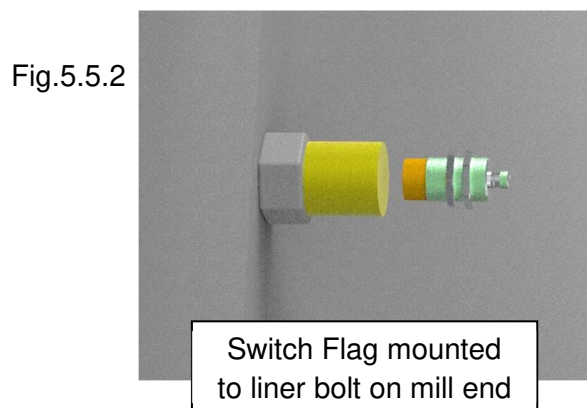

Switch Flag mounted to liner bolt on mill end

Fig. 5.5.3 Typically used proximity sensor as Rotation Sensor IIS268, max. Sensing Distance 30mm



5.6 Run-Out Monitor Controller

The controller is water and dust tight and made to be placed near the mill or the kiln. Nevertheless, make sure it is not exposed directly to the heat radiation from the kiln. Install the heat shield if needed.

For quick installation the controller can be attached by strong magnets e.g. to the bearing or girth gear housing, to the base frame or to a pole.

For bolting, use four M5 Allen bolts, going through the housing.

As an option, it is also possible to mount the Run-Out Monitor controllers in an electrical cabinet together with the power source and the I/Os from the plant control system.

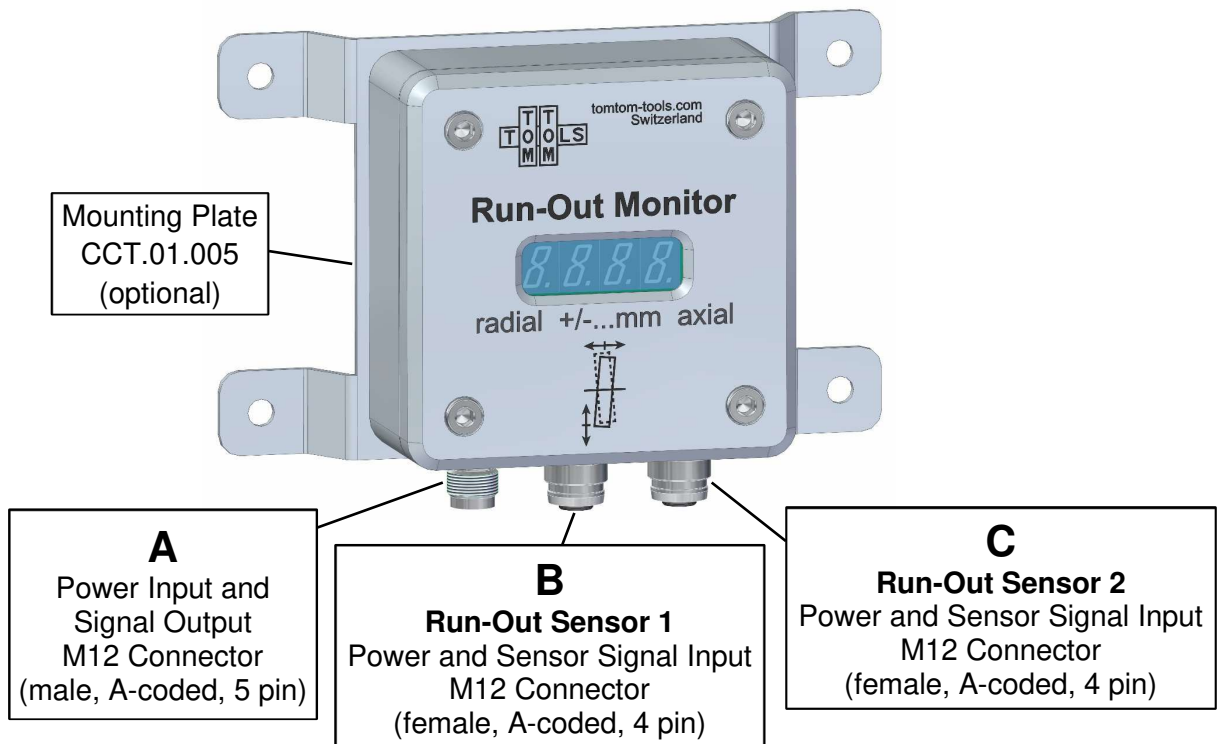

6 WIRING

The Run-Out Monitor is pre-wired from the terminal blocks on the circuit board to the M12 (A-coded) connectors on the housing.

The numbering and color coding are in Accordance with IEC 61076-2-101.

Pin No.	1	2	3	4	5
Color	Brown (BN)	White (WH)	Blue (BU)	Black (BK)	Grey (GY)
Connector A (X1)	Power Input + 24VDC (12...30VDC)	Signal Output 4...20mA Radial Run-Out	GND	Reference Signal Input Rotation Sensor	Signal Output 4...20mA Axial Run-Out
Connector B (X3)	Run-Out Sensor 1 Power Supply	Run-Out Sensor Input 4...20mA	GND	n.c.	n.c.
Connector C (X2)	Run-Out Sensor 2 Power Supply	Run-Out Sensor Input 4...20mA	GND	n.c.	n.c.

Fig. 5.4.1: M12 Connector (A-Coded) View from Front Side

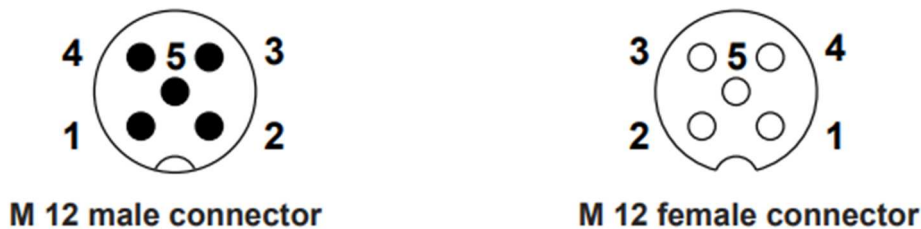
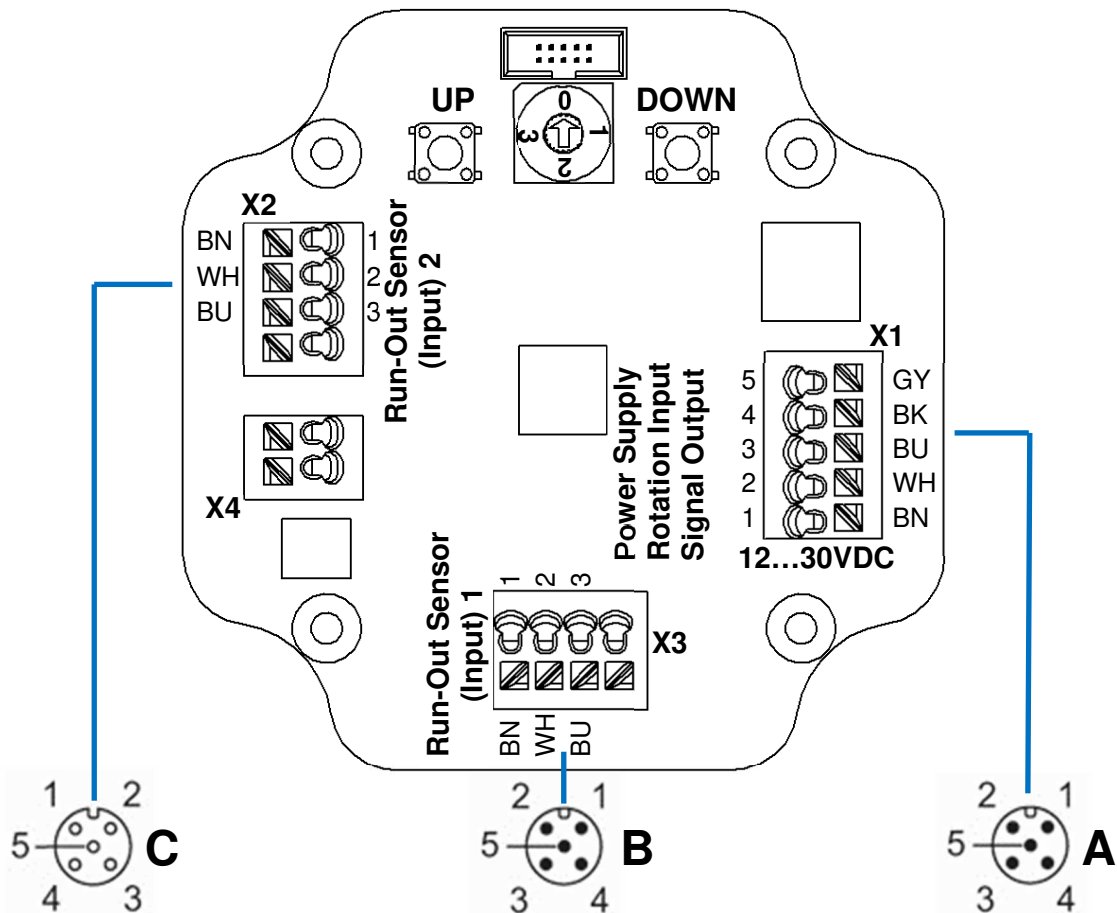

Fig. 6.0.1: Back side of circuit board in Run-Out Monitor



6.1 Wiring for Gear Run-Out Monitoring

The two Gear Sensors are connected to the controller of the Run-Out Monitor to the plug B and C. It does not matter which sensor connects to B or to C.

The power supply is connected to the plug A, from where also the two analog output signals are provided.

Fig. 6.1.1:

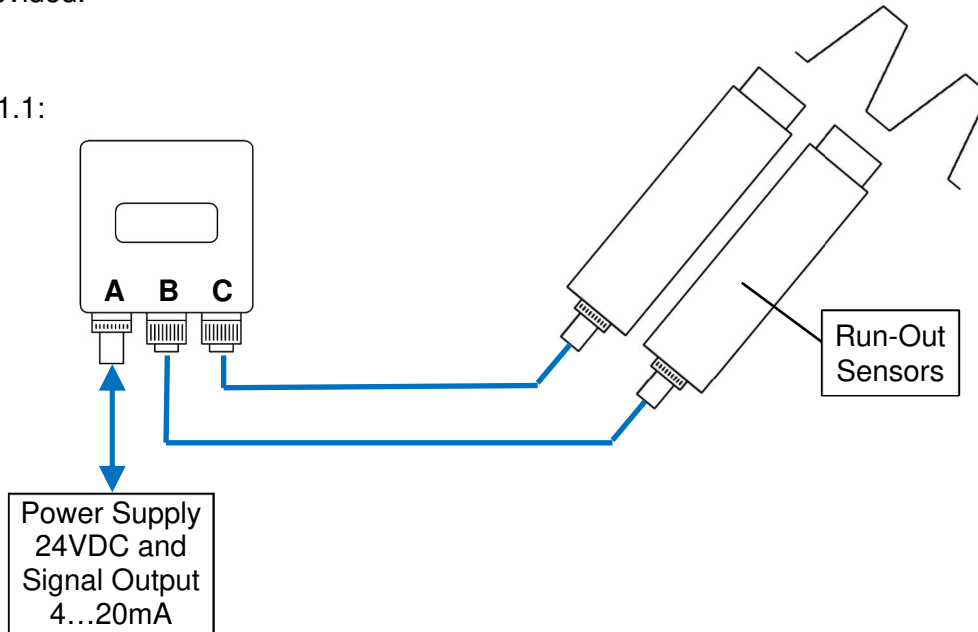

6.2 Wiring for Run-Out Monitoring of continuous surfaces

Measuring on continuous surfaces requires a rotation signal.

That is why a Reference Sensor is connected to the controller additionally to the Run-Out Sensors.

Fig. 6.2.1:

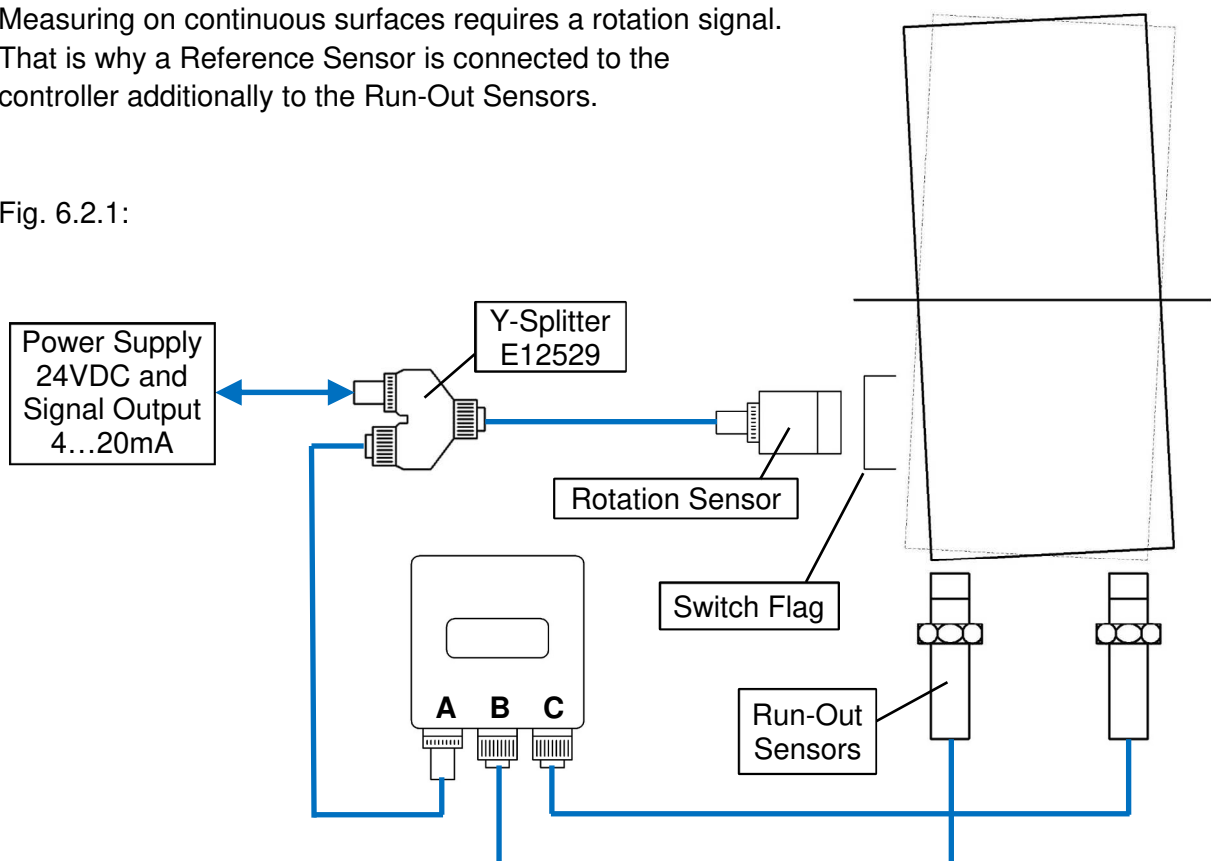

To feed the signal of the Rotation Sensor to the controller, use the following Y-Splitter M12-A (with 5 pins): IFM E12529

Fig. 6.2.2: Y-Splitter



6.3 Power Supply

Only one single 24VDC (1A) power source is required for one or two Run-Out Monitor units on a kiln or a mill. The power consumption varies a bit and depends on the sensor size which are used.

6.4 Rotation Signal

The rotation signal is provided by the Rotation Sensor as shown in Fig. 6.2.1. The rotation signal can be used by more than one Run-Out Monitor; it can be shared. The signal (pulses) is fed via pin 4 (black wire) together with the power supply to the connector A.

Note: On a rotary kiln, when a Creep Monitor or Travel Monitor is already installed, the existing reference signal can be used.

6.5 Run-Out Measurement

The run-out is measured by two inductive distance sensors. They provide an analog signal (4...20mA) on pin 2 (white wire) according to the distance to the measured surface.

The sensors must be connected to the controller via Connector B and C, as shown in Fig. 6.1.1 or 6.2.1.

The sensors should be installed with a distance of approximately half of the measuring range. That means, if a sensor measures from 0.8...8mm, the distance to the surface should be adjusted to ~5 mm. When a sensor reaches the end of its range, the message “dist” will be displayed.

Note: The different sensors and ranges are shown in the table in Chapter 4.3

Fig. 6.5.1: Distance Warning

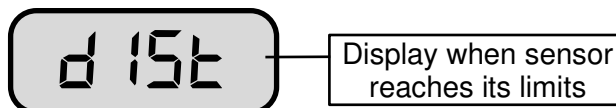
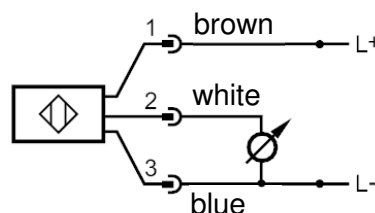

Fig. 6.5.2: Analog sensor wiring schematic



6.6 Run-Out Sensor Overview

The following sensors and fittings are typically used in combination with the Run-Out Monitor, but other sensors with analog output of 4...20mA might also be used; depending on space requirements and availability.

Application	Type:	Thread Size	Range	Linearization
Mill Trunnion	IF6030	M12x1	0.4...4mm	0.225mm/mA

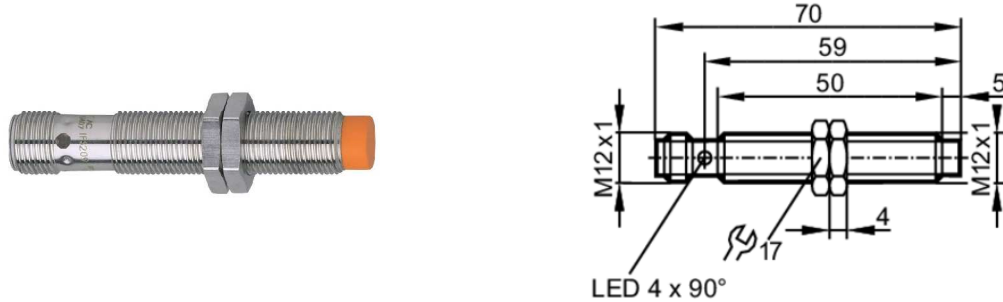

Application	Type:	Thread Size	Range	Linearization
Mill Girth Gear and Slide Shoe Track	IG6083	M18x1	0.8...8mm	0.45mm/mA

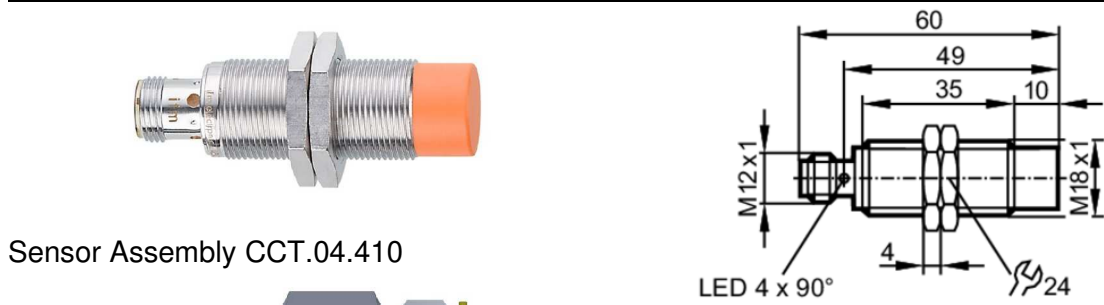

Sensor Assembly CCT.04.410

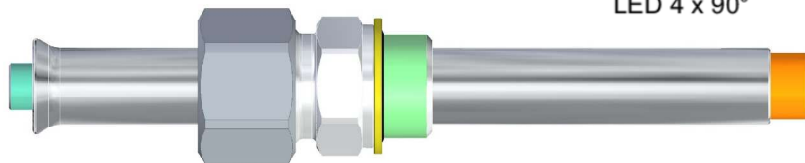

Application	Type:	Thread Size	Range	Linearization
Kiln Girth Gear and Tire	II6913 or II5913	M30x1.5	1...15mm	0.875mm/mA

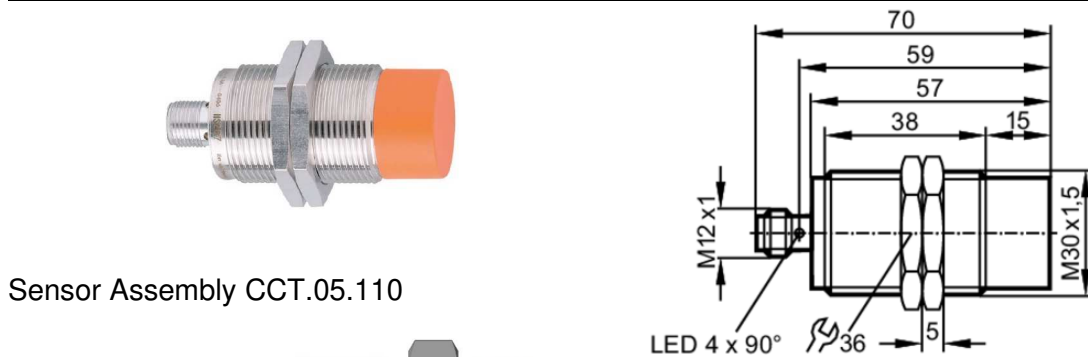

Sensor Assembly CCT.05.110



6.7 Signal Output

The controller is calculating the run-out from the signals of the run-out sensors. The average of the variation on both sensors represents the radial run-out, the deviation between the two signals represents the axial run-out (wobble). These two analog outputs (4...20mA) are available on the terminal block X1 and on the connector A.

Fig.6.7.1

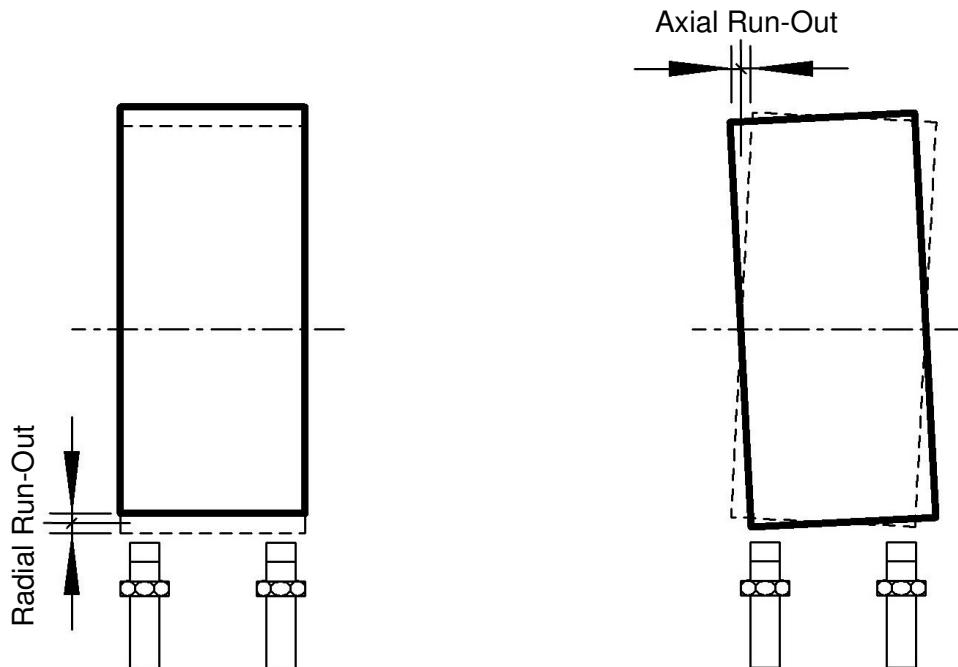

Note:

The Run-Out values represent the deviation of the straight running center position, which lays in the middle between the two peaks. That is why the run-out are shown as +/- values which is half of the Peak-to-Peak value.

Sensor Linearization Factor:

The range of the output signal depends on the sensor range, that is defined by the **Sensor Linearization Factor (Lin)**.

This factor (Lin) is shown in the table in **Chapter 4.3** and is calculated the following way:

$$Lin \left[\frac{mm}{mA} \right] = \frac{(max.Sensor\ Distance - min.Sensor\ Distance)}{16mA}$$

The following table shows how the range of the output signal is adapted to the sensor range:

Sensor Linearization (Lin) [mm/mA]	Output Signal [mA]	Radial Run-Out [mm] (X1: Pin2)	Axial Run-Out [mm] (X1: Pin5)
$Lin < 0.25$	4...20	0.0...+/- 2.0mm	0.0...+/- 4.0mm
$0.25 \leq Lin < 0.50$	4...20	0.0...+/- 4.0mm	0.0...+/- 8.0mm
$0.50 \leq Lin$	4...20	0.0...+/- 8.0mm	0.0...+/- 16.0mm

Attention: older software versions, **before 1.39** had the same mA signal output for the axial run-out as for the radial run-out

Example:

By using the sensor IG6083 with a range of 0.8...8.0mm, the Sensor Linearization Factor is $Lin=0.450\text{mm/mA}$.

Hence, the range of the output signal 4...20mA will represent 0.0...+/-4.0mm in radial direction and 0.0...+/-8.0mm in axial direction.

A radial run-out of +/-1.2mm would result in 8.8mA on Pin 2 (white wire)

An axial run-out of +/-3.5mm would result in 11.0mA on Pin 5 (gray wire)

Fig. 6.7.2: Alternating Display

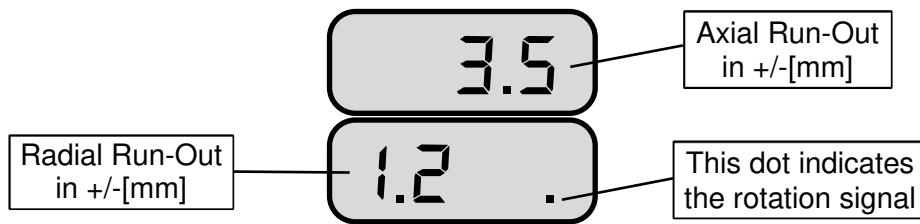

The current loops on Pin 2 and Pin 5 are based on the common ground (GND) on Pin 3 (blue wire)

Fig. 6.7.3: Terminal Block X1

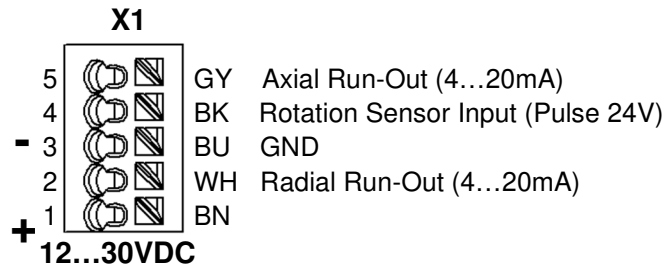

Note:

If the values cannot be calculated or when the machine is not rotated for more than 60sec the display will change to “- - -” and the output signals will be at the maximum, at 20mA.

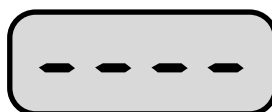

7 CONFIGURATION

The Run-Out Monitor can easily be configured by using the rotary switch to select the parameter and the UP and DOWN button to change the values.

Fig. 7.0.1:
Configuration Switch and Buttons

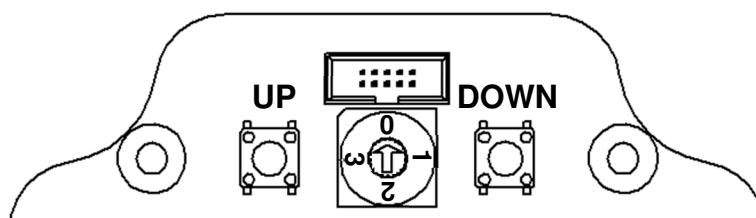

Normal operation: rotary switch position "0"

7.1 Number of Teeth



To measure the run-out of gears, the number of teeth has to be set, that the controller knows when a full turn is made. This parameter is reached by turning the rotary switch to the position 1.

Here in the example the girth gear has 276 teeth.

To change the value, push the UP or DOWN button as required.

(possible range: 0 to 9999 pulses per kiln turn)

Monitoring of Continuous Surfaces



Note: to measure continuous surfaces, the number of teeth needs to be set to 0; then the digital input (X1, Pin 4) is activated to receive the signal from the Rotation Sensor.

7.2 Diameter to Sensor Distance Ratio



The axial run-out is based on the difference between the two radially located sensors. The diameter, of a girth gear for example, is much larger than the sensor distance, that is why this diameter to distance ratio has to be considered for the calculation.

Put in the ratio (diameter D to sensor distance d) by turning the rotary switch on position 2 and using the UP and DOWN buttons.
(Range: 1.0...99.9)

Example:

Girth Gear Diameter D = 5m

Sensor Distance d = 0.4m

Ratio = $D/d = 5m / 0.4m = 12.5$

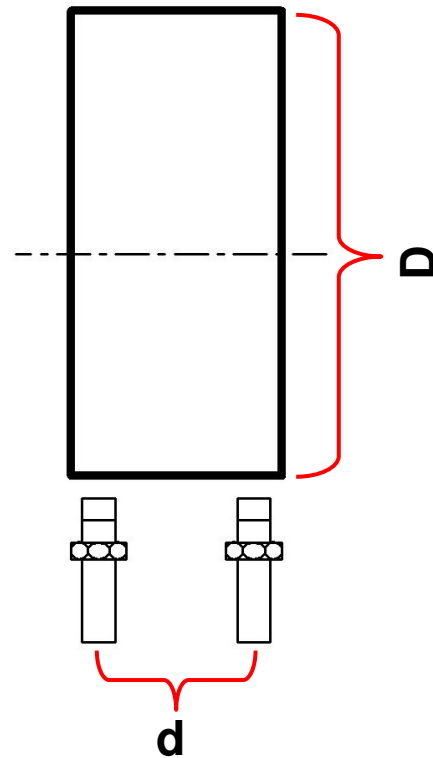

Note:

The aim is to place the Run-Out Sensors as far as possible apart from each other to get the Sensor Distance **d** high and the ratio low. The larger the ratio, the lower is the accuracy of the axial run-out.

7.3 Sensor Linearization



To make it possible to use the same controller with different sensors for a variety of applications, the software needs to know the sensor linearization. To edit it, turn the rotary switch to position 3 and adjust the value by using the UP and DOWN button.

The here shown linearization factor of 0.450mm/mA corresponds with the example described in chapter 6.7 using the 18mm sensor IG6083 (measuring range: 0.8...8.0mm)

