

User Manual

Version 16, March 16, 2026

Kiln Axis Alignment System

1 Introduction

The TomTom-Tools Kiln Axis Alignment system is an easy and fast way to verify the straightness of rotary kilns or dryers. The combination of a modern Robotic Theodolite, the powerful software and the unique Accessory Kit facilitate the measurement in a way that no longer special surveying knowledge is needed; without compromise on accuracy.

The alignment check of the kiln axis is one of the most important measurements on rotary kilns or dryers with more than two piers. The straightness of the kiln axis needs to be within tight tolerances to minimize the stress in the kiln shell and to distribute the support loads correctly among the different piers. Typical symptoms for misalignment are circumferential cracks in the kiln shell (near middle tire) and issues with the bearings of the support rollers.

Application Video: <https://www.youtube.com/watch?v=KLGX1OvhyUY>

1.1 Safety

Rotary kilns and dryers, where this tool is typically used, are huge rotating equipment with many pinch points and hot surfaces which can cause serious injuries. Therefore, only specialized and trained personnel shall work close to these machines. To use the tool, follow strictly the local safety rules given by the respective plant / factory / local authorities and discuss the application with the safety engineer in charge.

The tools provided by TomTom-Tools Ltd. have proven their functionality in various applications; nevertheless TomTom-Tools Ltd. does not take any responsibility for the application on site regarding safety. The plant is responsible for the safety, according to the local law, in a way that nobody can be hurt or injured. The application and safety instructions below are guidelines and not exhausted which include the experience from previous measurement campaigns and might need to be adapted to the local safety requirements.

Caution:



Laser Beam:

Laser radiation, do not stare into beam
Please consult the safety instruction in the manual of the Laser Theodolite.



Magnet Fields:

Be aware of the strong fields of the magnets
Keep the tool away from people with pace makers or any other sensitive item as credit cards or magnetic data carrier.



Gloves:

Wear proper gloves to protect your hands from hot and rough surfaces and sharp edges.



Hot Surface:

The kiln shell might be very hot. Do not touch it and keep sufficient distance.



Radio Waves:

Be aware of the radio waves (Bluetooth) which are emitted from the tool, as well from the Bluetooth adapter on the computer.
Do not keep the tool unnecessary in operation; switch it off, after usage.



Pinch Points:

Do not put your hands nor any items close or into pinch points (e.g.kiln tires / support rollers, girth gear / pinion,...)
Keep safe distance to avoid getting caught by moving parts.

Table of content

1	Introduction	1
1.1	<u>Safety</u>	1
2	Measuring Principle	4
3	Supported Theodolites and Licensing	4
4	Measurement Setup	5
4.1	<u>Station (Location of Theodolite)</u>	5
4.2	<u>Reference Points</u>	6
4.3	<u>Target Axle</u>	7
4.4	<u>Radio Intercom</u>	8
4.5	<u>Tablet PC</u>	8
5	Software:	9
5.1	<u>Software Installation:</u>	9
5.2	<u>Bluetooth Adapter (optional)</u>	9
6	Start the Tool:	10
6.1	<u>Set up the Total Station</u>	10
6.2	<u>Connect the theodolite (Total Station) with the PC</u>	11
7	Measurement:	12
7.1	<u>Open a new Project</u>	12
7.2	<u>Enter some kiln data</u>	12
7.3	<u>Measure the Reference Points</u>	13
7.4	<u>Measure the points on the tires</u>	15
7.5	<u>Verify Station</u>	19
7.6	<u>Relocate the theodolite to Station 2</u>	20
7.7	<u>Measure the Reference Points from Station 2</u>	20
7.8	<u>Measure the tires from Station 2</u>	21
7.9	<u>Coverage and Reliability Number (the “Quality” values for each tire)</u>	21
8	Evaluation of the Results	22
8.1	<u>Selection of the Anchor Points</u>	22
8.2	<u>Deviation of the Kiln Axis</u>	22
8.3	<u>Visualisation of the Kiln Axis</u>	24
8.4	<u>Tire Clearance Height Compensation</u>	25
9	Thrust Roller Alignment Check	25
9.1	<u>Position of Theodolite</u>	25
9.2	<u>Add a Station</u>	25
9.3	<u>If number of Reference Points is not sufficient</u>	25
9.4	<u>Prepare the Measurement Studio for the Thrust Rollers</u>	26
9.5	<u>Placing the 360° Prism</u>	26
9.6	<u>Measurement of Thrust Roller Center</u>	27
9.7	<u>Measurement Result</u>	28
10	Support Roller Alignment Check	29
10.1	<u>Placing the Prisms</u>	29
10.2	<u>Measurement of Support Roller Axis</u>	31
11	Components and Dimensions	32
11.1	<u>Target Axle</u>	32
11.2	<u>Ball Swivel</u>	33
11.3	<u>Prism Holder</u>	33
11.4	<u>Base Magnet</u>	34
11.5	<u>Base Disk</u>	34
11.6	<u>360° Prism</u>	34
11.7	<u>Rotation Adapter</u>	35
11.8	<u>Shaft Center Adapter</u>	35
12	List of Components	36

2 Measuring Principle

This Kiln Axis Alignment System is a specialized surveying method which is based on measured points in the 3D space, on and around the kiln. The required points are measured with a state-of-the-art laser theodolite with robotic function; a so-called Total Station.

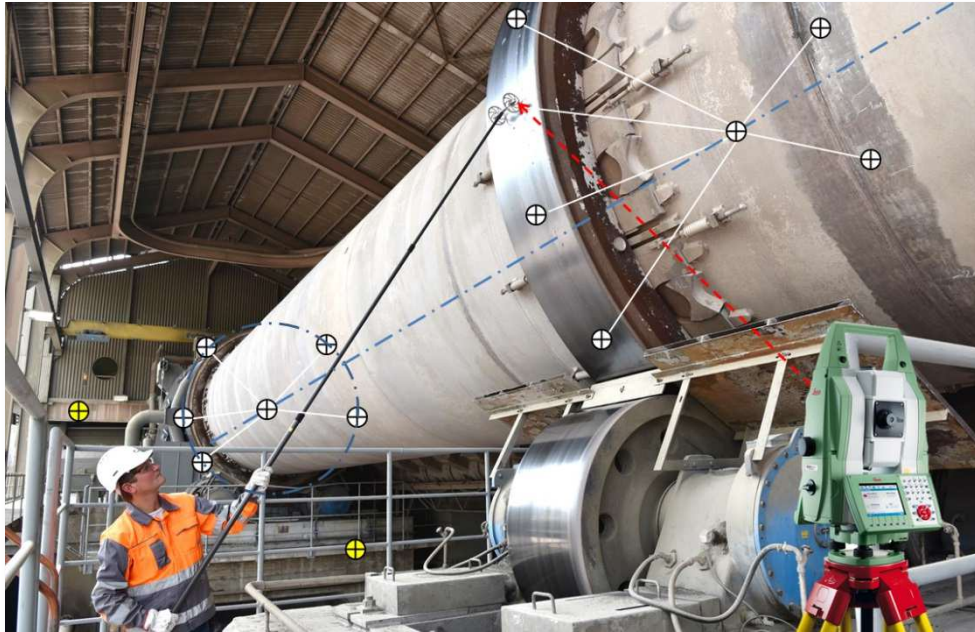

The software, the Measurement Studio, fits ideal circles / ellipses into the measured points, calculates automatically the centers of the tires and provides their deviation to a straight line. This deviation of the actual kiln axis to the straight line is the value for how much the kiln is misaligned.

In order to achieve the required accuracy of +/- 1...2mm, the kiln axis has to be measured from both sides of the kiln; therefore, two measurement locations (called stations) are required.

For the calculation, two types of points need to be measured, the reference points to combine / merge the different stations and the tire points to calculate the tire centers. A great feature of the here used theodolites is the automatic target recognition (ATR), which works perfectly with our target prisms and allow precise measurement without specialized surveying knowledge.

The kiln axis can be measured during normal operation as well as in stopped condition

3 Supported Theodolites and Licensing

Up to now, the following theodolites (Total Stations) are supported: **Leica TS60**, MS60, TS50, MS50, TS20, TS16, TS15. More brands and models will be added in future.

The TS60 is the recommended model due to its precision and tracking capabilities. Make sure the GeoCom Robotic Interface is activated. Please contact your local Leica dealer to get the activation key.

Needed:	827664	GeoCom Robotics TS/MS License key
Not needed yet	827663	GeoCom Imaging TS/MS License key
Not needed yet	827665	GeoCom Video Streaming TS/MS License key
Not needed	827666	Virtual GeoCom TS/MS License key

To activate your theodolite in the Measurement Studio please send the type and the serial number of the theodolite to info@tomtom-tools.com. The activation of one theodolite is part of the tool kit. The number of users and PCs is not limited.

4 Measurement Setup

The proper setup of the kiln axis measurement is the key point where most attention should be paid. Some kilns are easy to measure, because there is a free view to all the tires on both side of the kiln. Some kilns are difficult to access because there are many obstacles like air ducts and walkways next to the kiln.

It is recommended to start and to become familiar with the axis measurement system on a kiln which is easy to access.

4.1 Station (Location of Theodolite)

A station is the location of the theodolite where it is placed to measure.

Two stations are typically required to measure the kiln axis of a rotary kiln; one station to cover the right side of the kiln and one station for the left side. In case the kiln is surrounded by obstacles, which do not allow the free view from one station to all the tires, additional stations are required.

Finding the “best” stations is the key to measure the kiln efficiently with high accuracy.

The following points should be considered while searching for stations:

- Is the place safe and free of dust?
- Is it not too hot for people or the theodolite?
- Can all kiln tires be seen?
- Is the place stable, not vibrating and not affected by people moving around?
Preferable, measure from the ground or from concrete structures
Steel structures might not be sufficiently stiff

The picture below shows the typical setup:

Fig.4.1.1

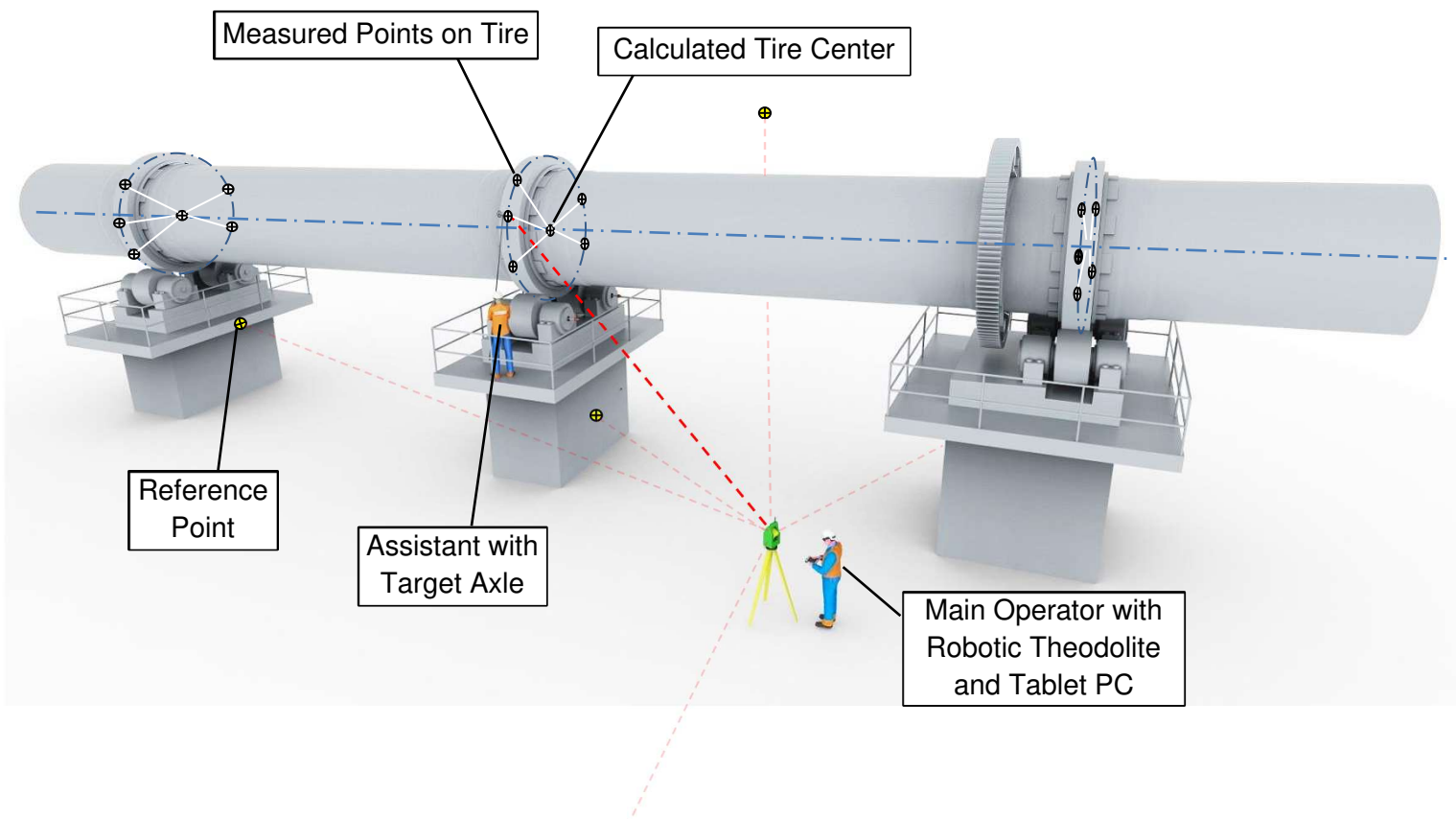

4.2 Reference Points ⊕

The Reference Points, sometimes also called “common points” are needed to merge the measurement points from different stations to one complete 3D model. Therefore, they have to be placed where they can be seen and measured by the theodolite from all the different stations.

Theoretically, there are only 3 common reference points needed to merge two stations. But each measurement of each point might have a small inaccuracy of about 1mm. That is why it is recommended to add more reference points; it will increase the final accuracy of the merged data. A good number of common reference points are 5. In case one got lost or shifted, there are still 4 points left, which should be enough.

Please respect the following rules for the reference points:

- a) Look for places which can be seen preferable from all the stations
- b) The reference points should be distributed around the kiln area in a way that the covered volume is as big as the kiln
- c) The reference points should be spread around the station in different directions
- d) Look for concrete and stiff steel structures
- e) Be careful on high thin steel structures they might vibrate or are affected by wind and temperature changes caused by the sunlight
- f) If there is the possibility, attach the reference points on steel structures close to the ground and concrete foundations where not much changes due to vibration and thermal expansion are expected.
- g) If reference points are attached to walk ways and platforms, make sure there are no relevant changes while people are moving.
- h) Do not attach reference points on crane structures in case it is in use, because the position might not be stable
- i) Make sure the base magnet is sticking sufficiently strong to the base material. In case there is too much dust or paint on the surface, clean it first to get sufficient magnetic hold.
- j) Attach the reference points to straight surfaces; do not attach them on round tubes as railings or posts

Typical locations for reference points are:

- Kiln piers (toe plates on railing close to concrete)
- Structure of walkways near the kiln (close to concrete base)
- Main structure of pre-heater tower
- Large silos
- Strong posts of railing (close to concrete)
- Window or door frames of buildings
- Roof structures

Note:

In the beginning it might be a bit difficult and time consuming to find good stations and the right spots for the reference points, but it is well invested time.

The following pictures show a reference point, which consists of the following components:
Fig.4.2.1

1. Base Magnet
2. Prism Holder
3. Ball Prism



The **Base Magnets** are very strong to keep the position without any movement during the measurement campaign. These Base Magnets could also remain at site, which would make the next time the setup quick and easy.

The **Prism Holders** are attached by another magnet to the Base Magnets. The Prism Holders maintain their center position and height, but can be turned freely around their vertical axis. This allows the adjustment of the prism into the direction of the theodolite. The 45° shape of the Prism Holders gives a maximal range to the Ball Prisms.

The **Ball Prisms** are reflectors which send the laser beam from the theodolite back to it. Therefore, the prisms have to be directed toward the theodolite. The spherical shape allows adjustments to the different stations without changing the position of the reference point, which is in the center point of the ball.

4.3 Target Axle

The Target Axle is used to acquire points from the outer diameter, the running surface, of the kiln tires. The axle is equipped with two ball prisms, the targets, whereof only one is used for the measurement at the time. The ball prisms are located in the center of the wheels, which results in a constant distance to the tire center independent on the position of the target axle. To facilitate the acquisition of points over large areas around the tire, the target axle is mounted on a telescopic pole. The target axle is placed by the assistant to different positions around the kiln tires. Sidewise, the prism in use should be located approximately in the middle of the running face of the tire.

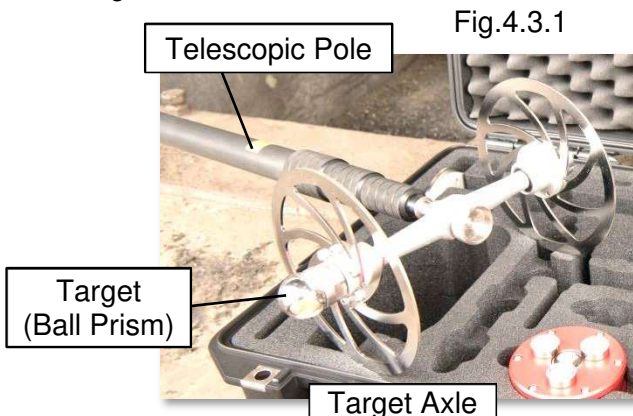

Fig.4.3.1



Fig.4.3.2

4.4 Radio Intercom

The communication between the main operator at the theodolite and the assistant at the kiln is crucial for safe and efficient work. Therefore, the tool kit is equipped with a pair of radio intercom headsets. The main operator can give easily instructions to the assistant where the target axle should be placed to have a clear view from the theodolite.

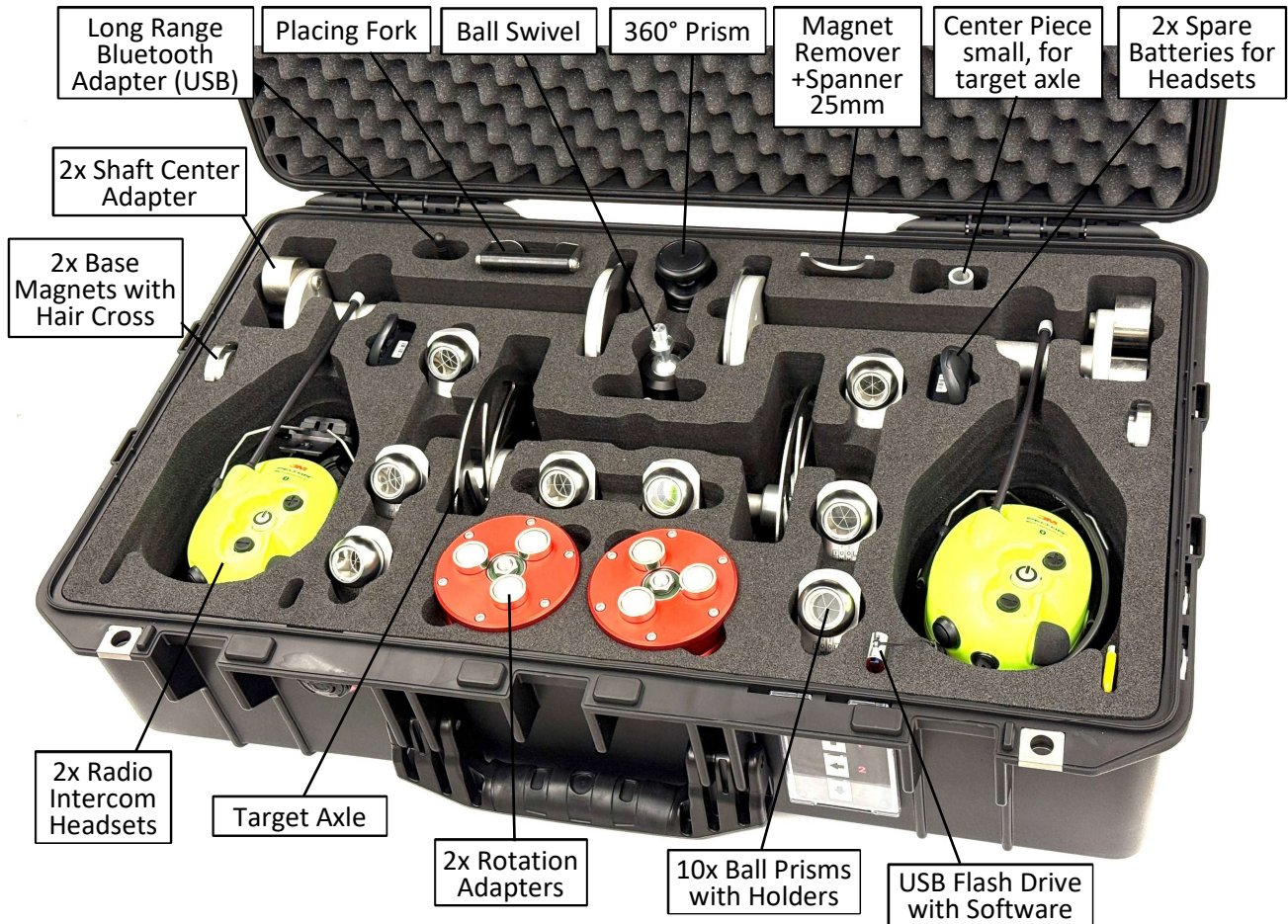

4.5 Tablet PC

In the scope of supply of the Kiln Axis Alignment Tool Kit is the following tablet PC included:

Panasonic FZ-G2 with the following extras:

- Integrated Long Range Bluetooth
- Large Battery for long working time
- Industrial key board (can be attached when required, e.g. for work in office)
- Mobility Bundle for easy carrying at site



Fig.4.5.1

Note: any other PC which is running with Windows 10 or higher can be used as well

5 Software:

5.1 Software Installation:

The software (**TomTom-Tools Measurement Studio**), which is used for the Kiln Axis Alignment and for all others of our tools, is pre-installed on the tablet PC and comes along with the tool kit on a USB Memory Stick. Nevertheless, it is highly recommended to **install the software from www.tomtom-tools.com**, where always the latest version is available.

During any start of the Measurement Studio, it is checking for updates if the computer is connected to the internet. In case of available upgrades the user gets asked if they should be downloaded and installed.

Please keep your PC up to date.

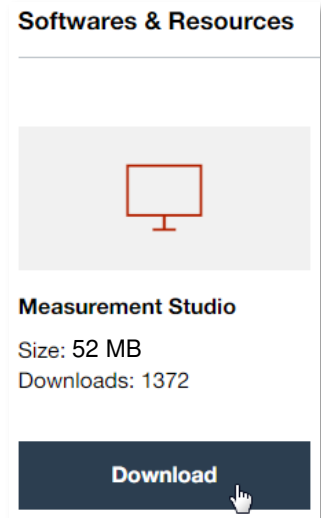

5.2 Bluetooth Adapter (optional)

To connect to the theodolite, the inbuilt Bluetooth of a normal Laptop PC is usually strong enough to establish a reliable connection, because only short distances are required. By using the Panasonic Tablet PC (FZ-G2) with the integrated Long-Range Bluetooth, large distances (>100m) can be reached easily.

It is also possible to reach large distances (>100m) with a regular PC, by using the Long-Range Bluetooth adapter (Sena UD100 or ZEXMTE), which comes along with the tool kit.

Note:

- To force the PC to connect via the Long-Range Bluetooth Adapter, the integrated Bluetooth needs to be disabled in the Device Manager as shown below. The Bluetooth Adapter communicates **only with the generic Windows Bluetooth Stack**. If there is another Bluetooth software installed (e.g. Intel, Toshiba, Widcomm, ThinkPad,...), **deactivate it**.

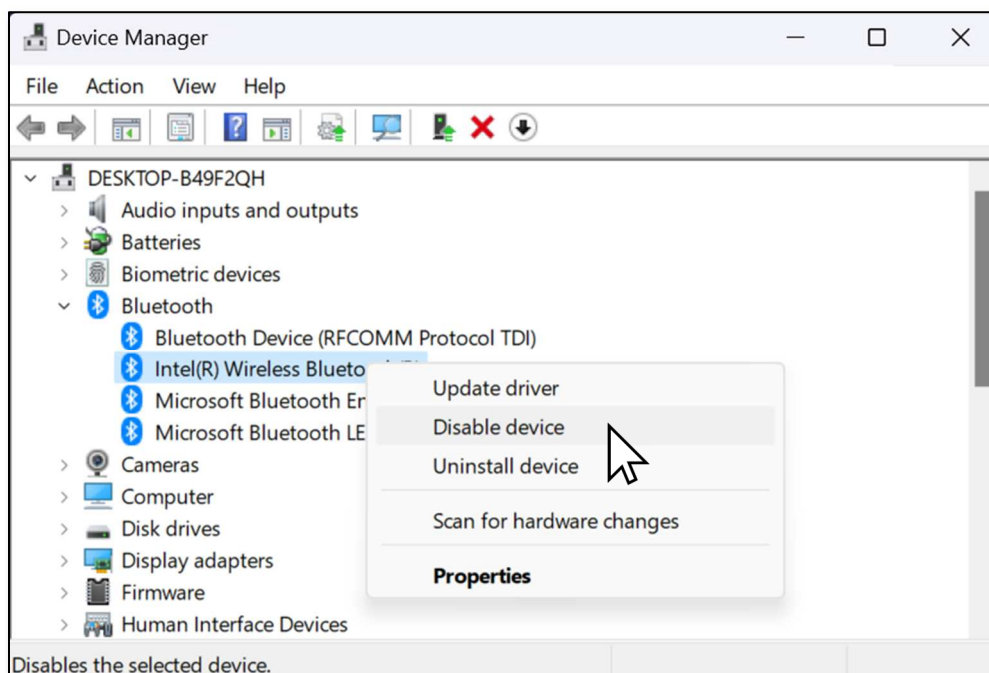

Fig.5.2.1
Device Manager

- Then plug the Bluetooth adapter ZEXMTE
Windows will recognize the new hardware
and automatically install the suitable Windows drivers
- The Device Manager will show the following:
 - Generic Bluetooth Radio
 - Microsoft Bluetooth Enumerator
 - the not required Bluetooth is down
(indicated by the small arrow at the Bluetooth icon)

Fig.5.2.3 Device Manager
(USB Bluetooth correctly working)

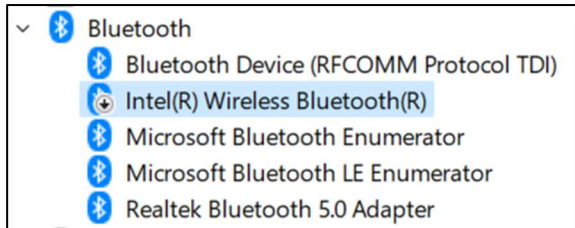

Fig.5.2.2

ZEXMTE Bluetooth Adapter Specifications:

- Bluetooth 5.1 and EDR Class 1 (dual mode)
- USB-A 3.0
- Frequency Range: 2.402 ~ 2.480GHz
- Antenna: RP-SMA

6 Start the Tool:

6.1 Set up the Total Station

Shield the instrument from direct sunlight and the heat radiation from the rotary kiln.
Avoid uneven temperatures around the instrument.

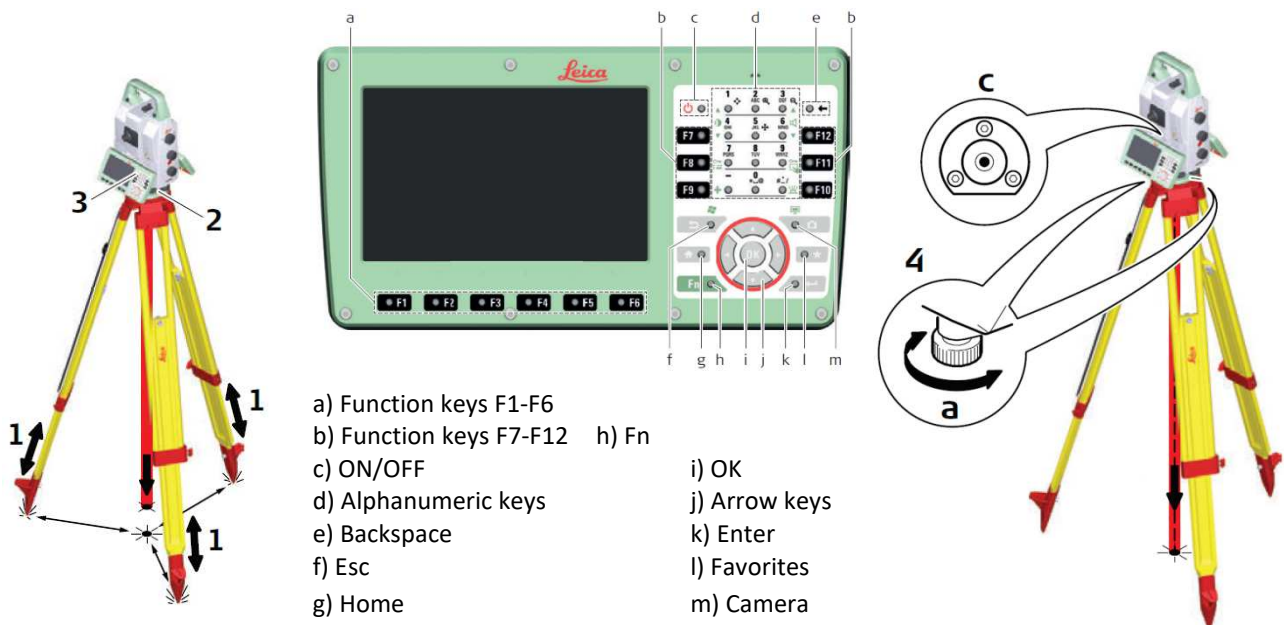

- a) Function keys F1-F6
- b) Function keys F7-F12
- c) ON/OFF
- d) Alphanumeric keys
- e) Backspace
- f) Esc
- g) Home
- h) Fn
- i) OK
- j) Arrow keys
- k) Enter
- l) Favorites
- m) Camera

Step Description

1. Extend the tripod legs to allow for a comfortable working posture.
Position the tripod at Station 1 (as described in chapter 3.1).
Ensure that the tripod plate is horizontal.
2. Fasten the tribrach and instrument onto the tripod.
3. Turn on the instrument by pressing the ON button (c).
Select **Settings/TS instrument/Level & compensator** to activate the electronic level.
4. Use the tribrach foots crews (a) to center the electronic level (b)

For more details please consult the user manual of the Leica Total Station

6.2 Connect the theodolite (Total Station) with the PC



Start the Measurement Studio on the computer by clicking on the icon. To connect the theodolite or any other tool for the first time it has to be paired with the PC. To do so, follow this sequence:

- Switch on the theodolite by pushing the ON button (c).
- At the PC, click on “Tools / Bluetooth Devices / Add a device”
- Wait until the tool got found
Note: Depending on the search speed of the computer, it might take up to one minute.
- Select the device, which has to be connected; (here the theodolite) and click “OK”

Fig. 6.2.1 (Add Device)

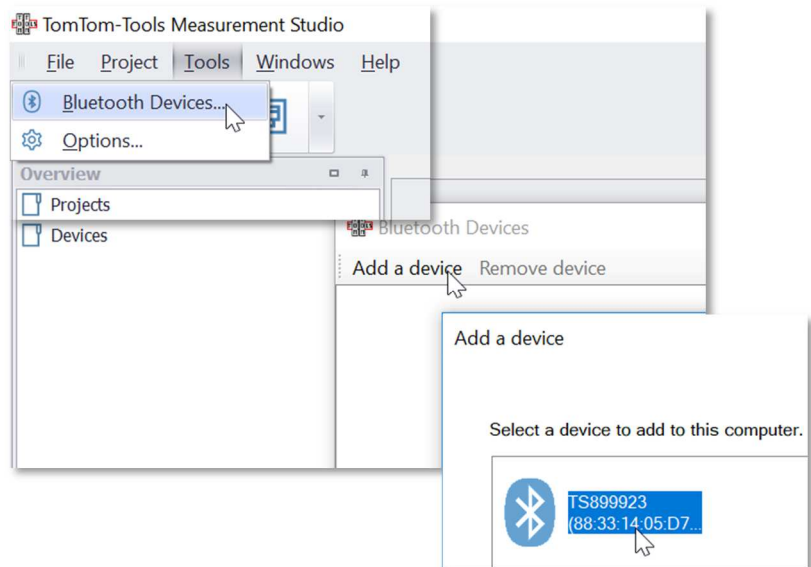

Fig. 6.2.2 (Connect Device)

- The theodolite is added to the Device List
- To connect the theodolite, click on the “Connect” Button

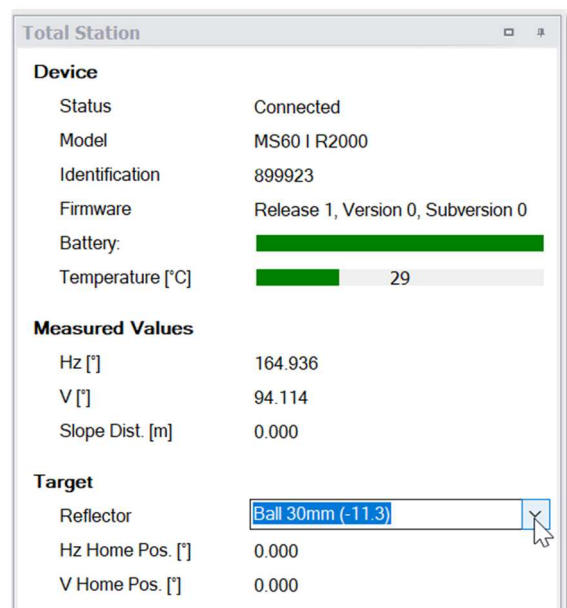
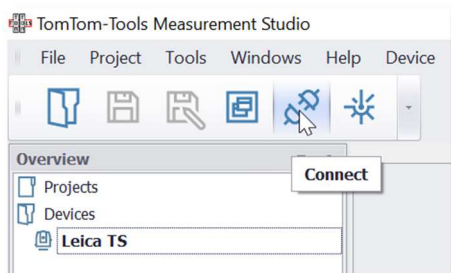

Fig. 6.2.3: Main Parameter of Total Station
 The main parameters are shown in the bottom window at the left side.

The ball prism which is used for the kiln axis measurement is selected by default **Ball 30mm** with the prism constant of -11.3mm (Leica: +23,1mm)

7 Measurement:

7.1 Open a new Project

A new project file has to be generated by clicking on “Project / Kiln Axis”

If there is an existing file, it can be opened and the Kiln Axis Measurement added.

Fig. 7.1.1

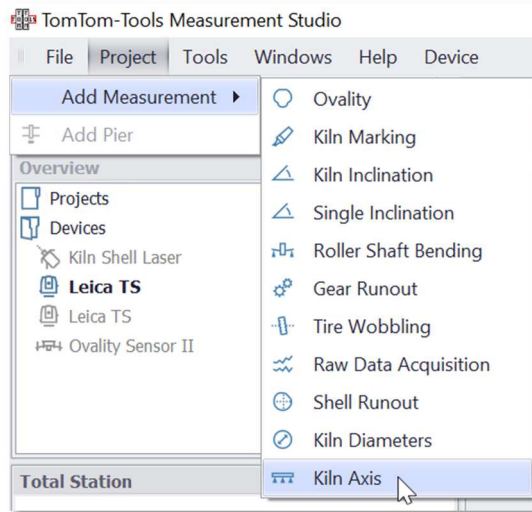

7.2 Enter some kiln data

In the Settings, the basic kiln data has to be entered.

To reach the settings, right click into the settings widow or navigate via the main buttons to “Project / Settings...”

Fig. 7.2.1

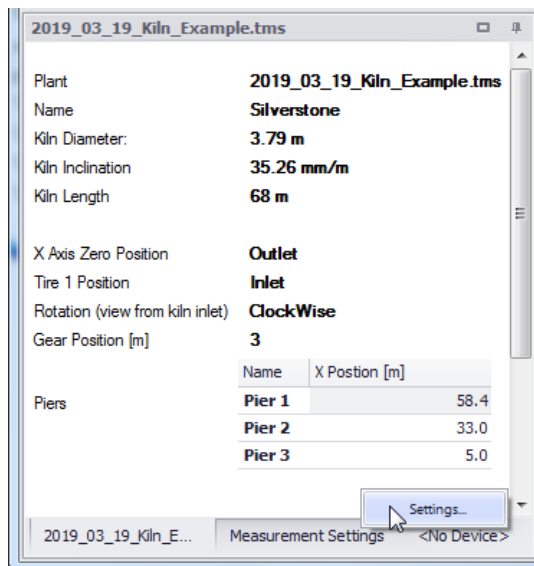

Fig. 7.2.2



Enter the following:

- Plant and kiln name
- Kiln Diameter
- Kiln Length
- X-Axis Zero Position (from where starts the meter counting, typically it counts from outlet)
- Tire 1 Position (state if tire 1 is at the inlet or discharge side of the kiln)

Note: The distance between the tires will be adjusted automatically according to the kiln axis measurements; therefore, the X-Position of only one tire has to be entered

7.3 Measure the Reference Points

The theodolite is placed at Station 1.

Now the reference points (common points) can be measured.

To do so, perform the following steps:

- Add a reference point in the software by clicking on the button “Add Reference Point”.
- To avoid any mix up of the reference points, it is recommended to change the name of the reference point to a unmistakable name (e.g. preheater tower, pier 2,...)
- Direct the theodolite manually towards the first reference point. It has not to be precisely therefore the rough finder on top of the theodolite or the laser pointer or the camera picture are sufficient to aim the theodolite to the reference point
- Make sure the ball prisms of the reference points are looking into the direction of the theodolite
- Click on the Start Button, or **[F5]**, or **[A1]** on the Panasonic Tablet PC
- The theodolite will search for the prism and the first Reference Point will be measured automatically. The coordinates are displayed in the table as shown in Fig. 7.2.3.

Fig. 7.3.1 (Add Reference Point)

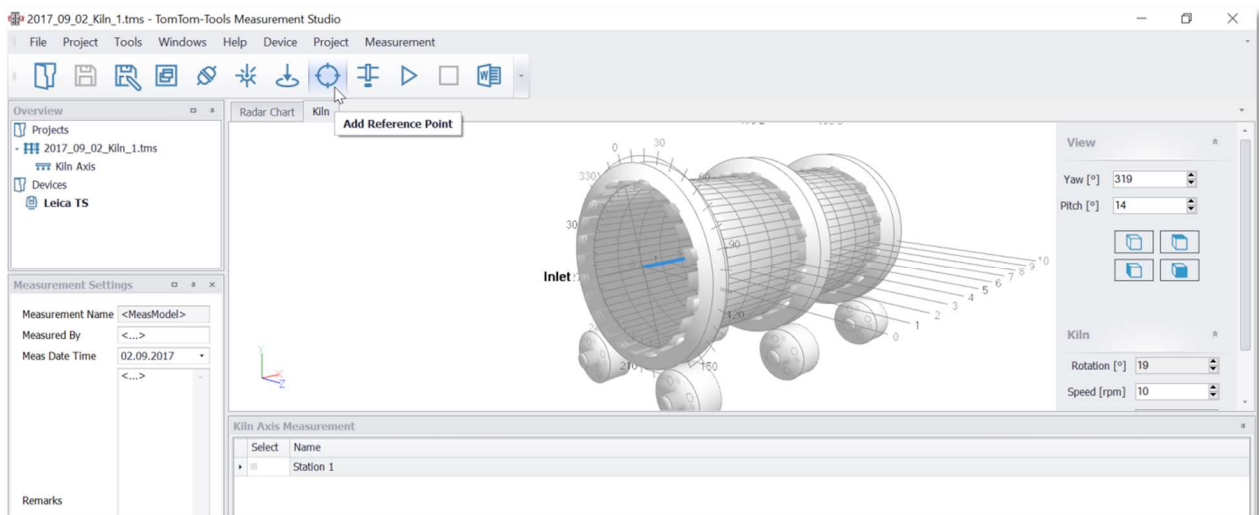

Fig. 7.3.2 (Activate the Laser Pointer)

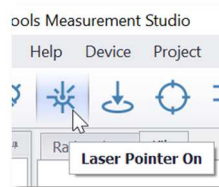
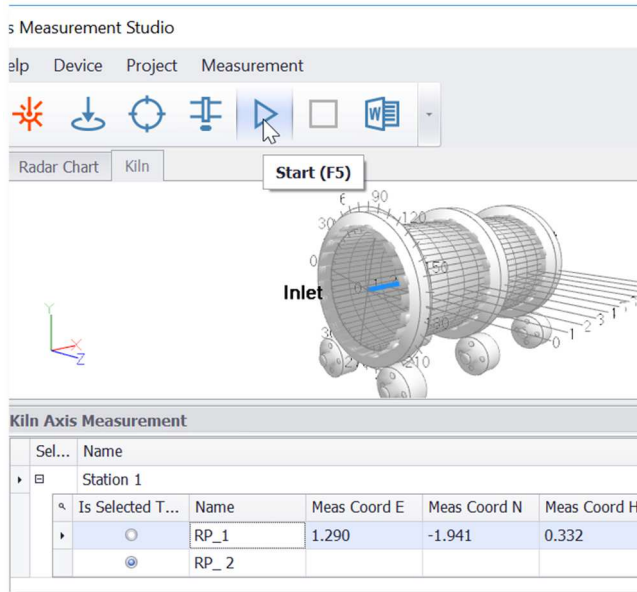

Fig. 7.3.3 (Reference Point 1 is measured)

Kiln Axis Measurement				
Select	Name	Meas Coord E	Meas Coord N	Meas Coord H
Station 1				
⊗	RP_1	1.290	-1.941	0.332

Measure all the Reference Points by repeating the above-mentioned sequences.

Fig. 7.3.4 (Start measurement of Reference Point 2)



*If you have a Panasonic tablet PC use the function buttons as shown here

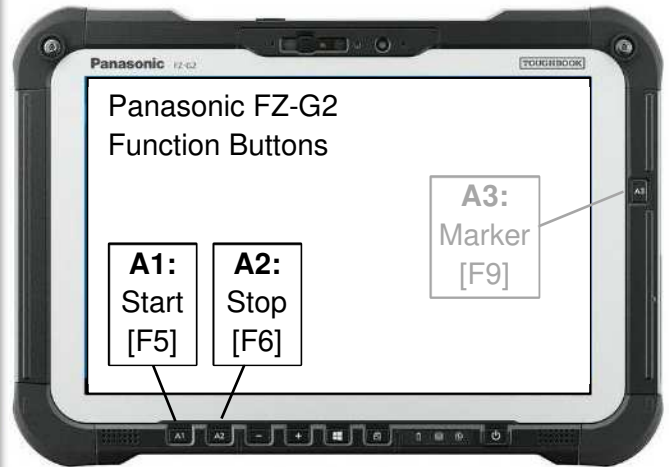

Tip: Save the file frequently

Fig. 7.3.5 (All Reference Points are measured)

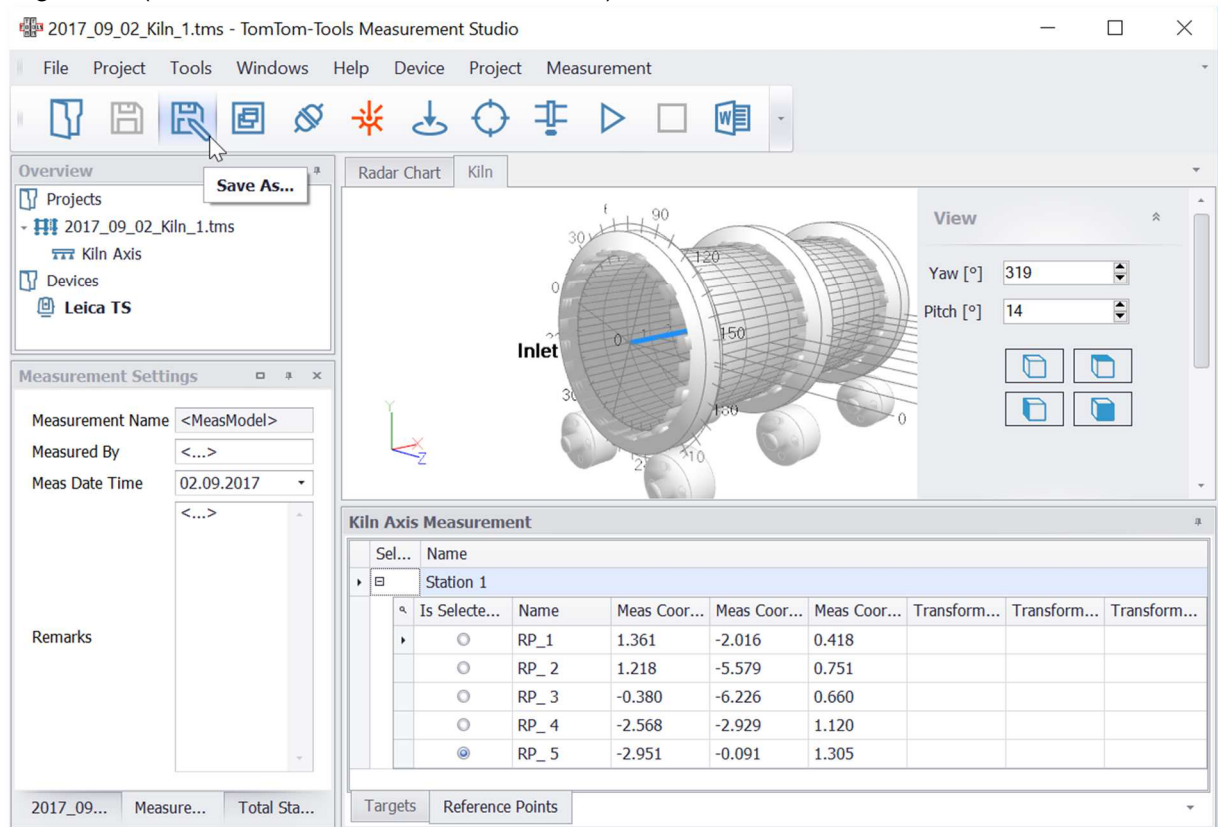

7.4 Measure the points on the tires

To measure the required points from the outer surface of the tire, the Assistant is up at the pier and holding the target axle via telescopic pole onto the tire, as described in chapter 4.3.

It is recommended acquiring about 8 points at each side of the tire.

Sometimes there are obstacles which do not allow to measure as per recommendation.

In that case increase the number of points where the access is given and check the “Reliability Number” (described later)

Fig.7.4.1 shows an example of measured points on a tire with full visibility from both sides of the kiln

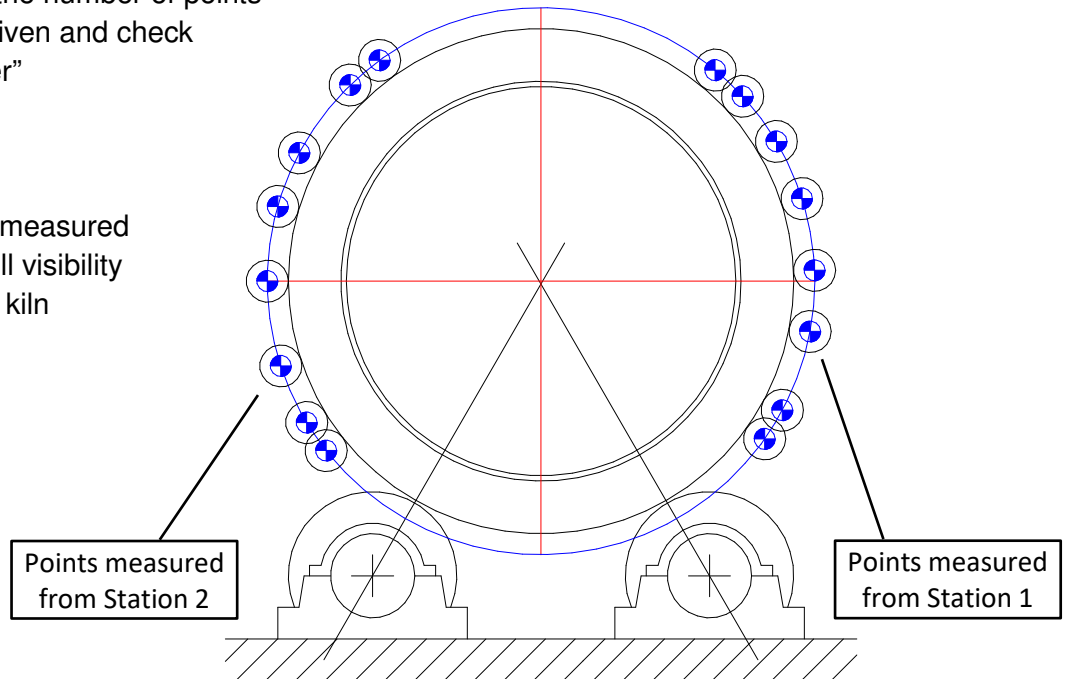

- Navigate in the Measurement Studio to the table with the tires by clicking on the Tap “Tires”
- Select the tire which will be measured
- Get the confirmation with the assistant by Bluetooth intercom that he is ready, the Target Axle is running stable on the tire and the prism is directed towards the theodolite.
- Aim the theodolite into the direction of the target axle and start the measurement by pushing the Start Button (or F5)

Fig.7.4.2 (list of tires with the select button)

Kiln Axis Measurement								
Name				Kiln Coord X [m]	Kiln Coord Y [m]	Kiln Coord Z [m]	Diameter [m]	Reliability
Tire 1	<input checked="" type="radio"/>			10.0	0.000	0.000		
Tire 2	<input type="radio"/>				0.000	0.000		
Tire 3	<input type="radio"/>			0.0	0.000	0.000		

Selected for Measurement

Tires Reference Points

Fig.7.4.3 (coordinates of points on Tire 1 measured from Station 1)

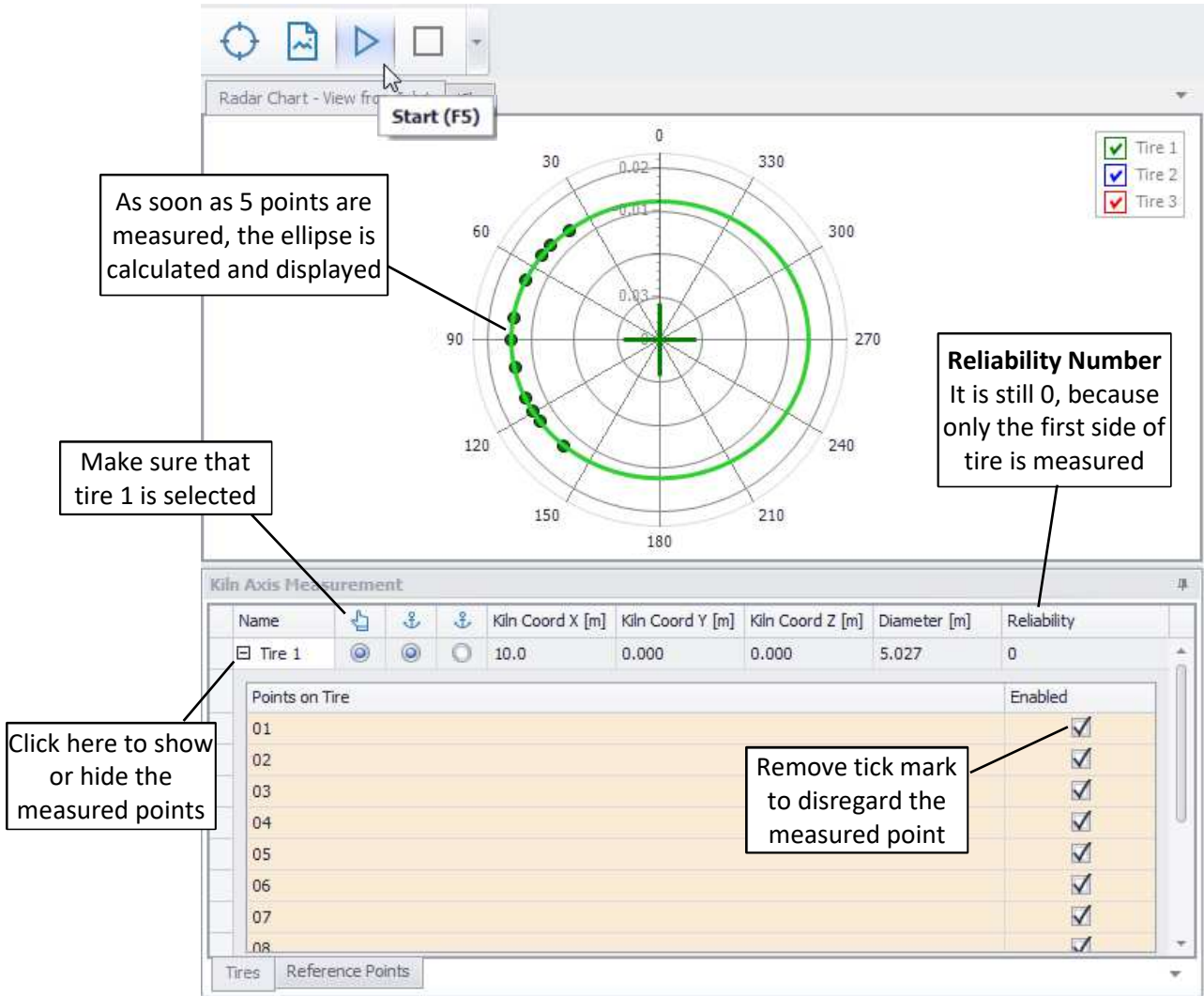

As soon as sufficient points are measured to establish the setup, it will be displayed in the 3D view as shown below:

Fig.7.4.4 Survey Information / Visualization of the Measurement Setup

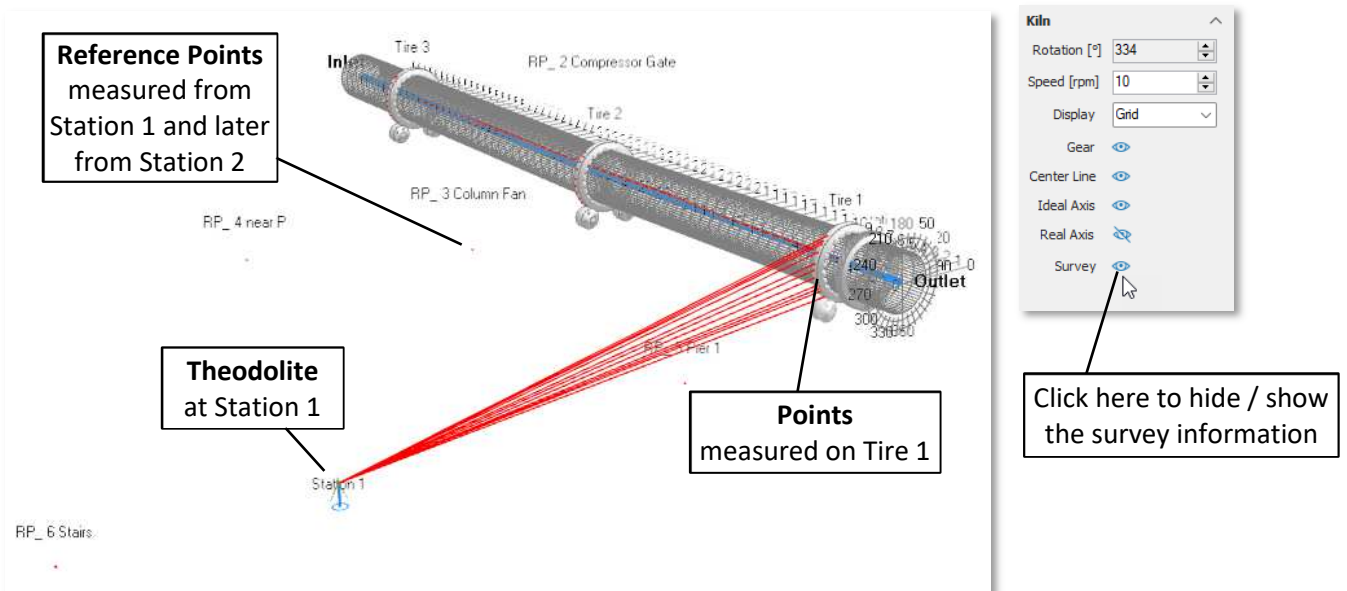

When the measurement on tire 1 is completed, select Tire 2 and measure the points on tire 2 the same way. Save the file (preferable under a new name)

Fig.7.4.5 (select Tire 2)

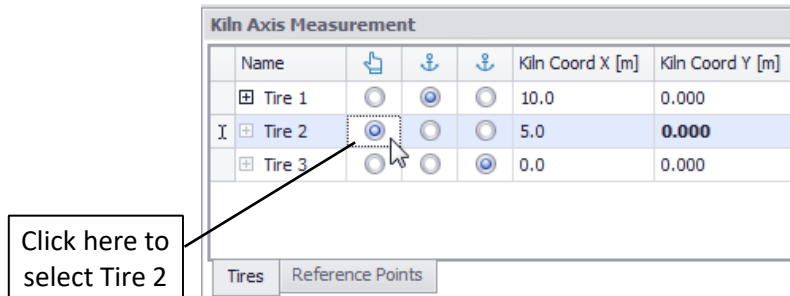
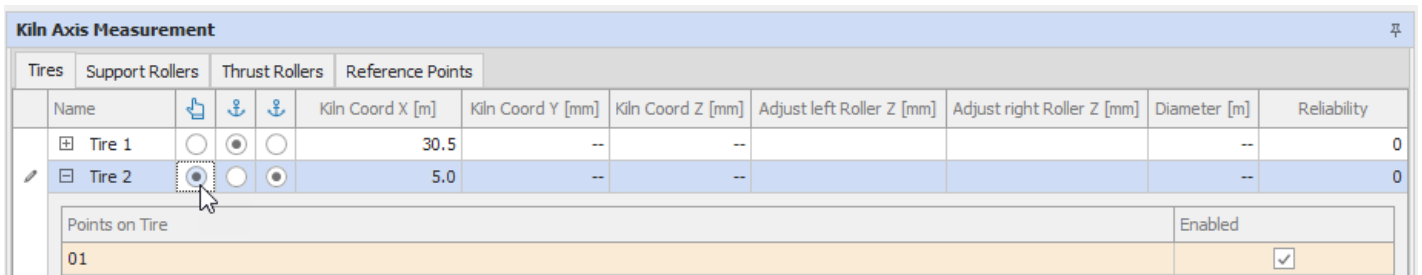

Fig.7.4.6 (First measured point on Tire 2)



When Tire 2 is measured, continue on the remaining tires until all are measured.

The 3D view will show all the rays from the theodolite to the measured points as in the screen shot below.

Fig.7.4.7 (All tires are measured from Station 1)

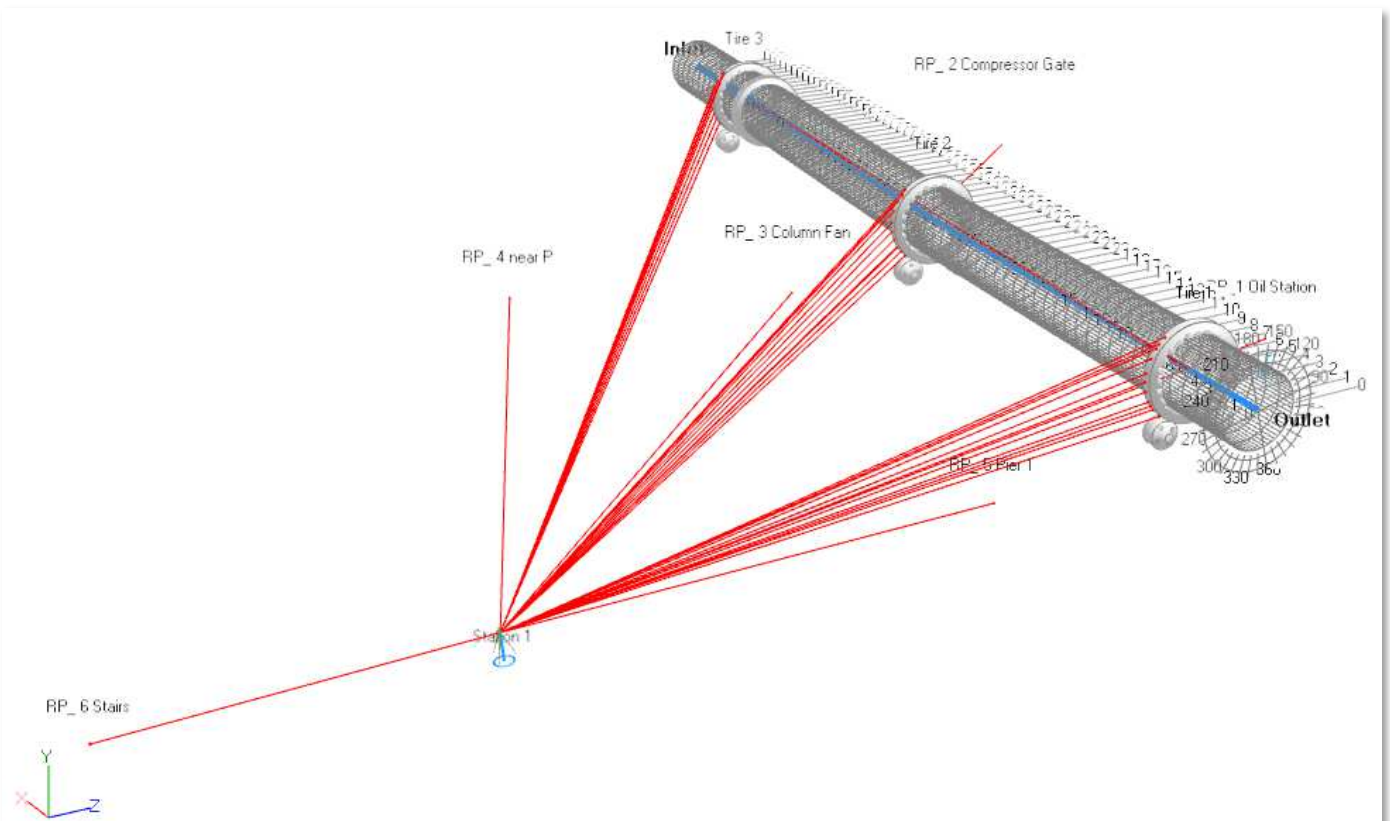

The list below is filled with the measured points of the different tires. To visualize a specific ray in the 3D model, click on the respective measurement point in the list.

Fig.7.4.8 (All tires are measured from Station 1)

Kiln Axis Measurement									
Tires	Support Rollers	Thrust Rollers	Reference Points						
Name			Kiln Coord X [m]	Kiln Coord Y [mm]	Kiln Coord Z [mm]	Adjust left Roller Z [mm]	Adjust right Roller Z [mm]	Diameter [m]	Reliability
▾ Tire 1	<input type="radio"/>	<input checked="" type="radio"/>	58.4	--	--			--	0
Points on Tire: Enabled									
01									<input checked="" type="checkbox"/>
02									<input checked="" type="checkbox"/>
03									<input checked="" type="checkbox"/>
04									<input checked="" type="checkbox"/>
05									<input checked="" type="checkbox"/>
06									<input checked="" type="checkbox"/>
07									<input checked="" type="checkbox"/>
08									<input checked="" type="checkbox"/>
09									<input checked="" type="checkbox"/>
10									<input checked="" type="checkbox"/>
11									<input checked="" type="checkbox"/>
▾ Tire 2	<input type="radio"/>	<input type="radio"/>	33.0	--	--	0	0	--	0
Points on Tire: Enabled									
01									<input checked="" type="checkbox"/>
02									<input checked="" type="checkbox"/>
03									<input checked="" type="checkbox"/>
04									<input checked="" type="checkbox"/>
05									<input checked="" type="checkbox"/>
06									<input checked="" type="checkbox"/>
07									<input checked="" type="checkbox"/>
08									<input checked="" type="checkbox"/>
09									<input checked="" type="checkbox"/>
10									<input checked="" type="checkbox"/>
▾ Tire 3	<input type="radio"/>	<input type="radio"/>	5.0	--	--			--	0
Points on Tire: Enabled									
01									<input checked="" type="checkbox"/>
02									<input checked="" type="checkbox"/>
03									<input checked="" type="checkbox"/>
04									<input checked="" type="checkbox"/>
05									<input checked="" type="checkbox"/>
06									<input checked="" type="checkbox"/>
07									<input checked="" type="checkbox"/>
08									<input checked="" type="checkbox"/>
09									<input checked="" type="checkbox"/>

Fig.7.4.9 Visualization of a specific measurement point on the tire

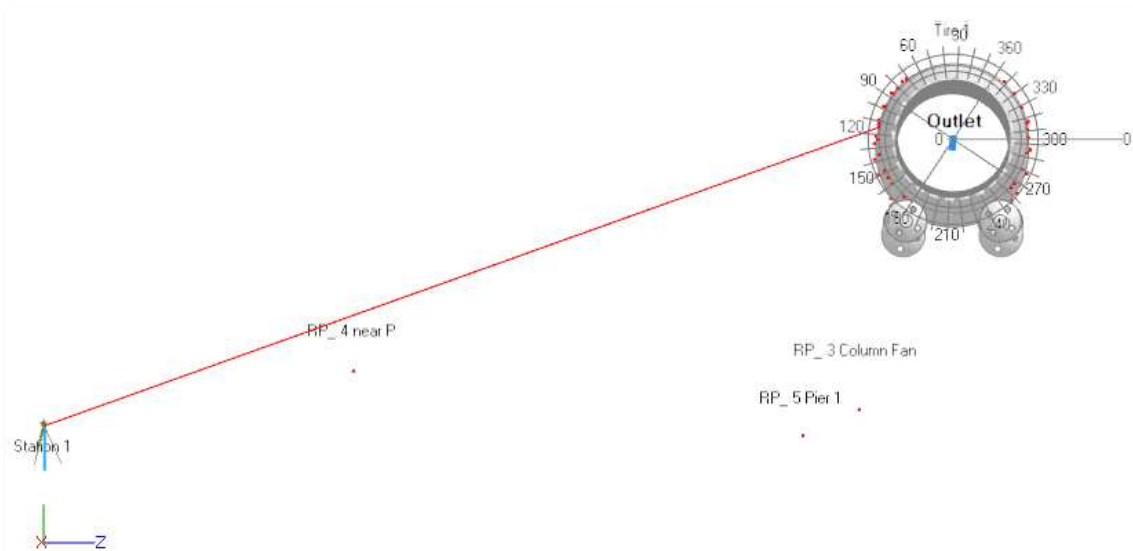

The points from the tires are also shown in the Radar Chart where possible errors can be identified.

Fig.7.4.10 (Radar Chart shows measured points on tires)

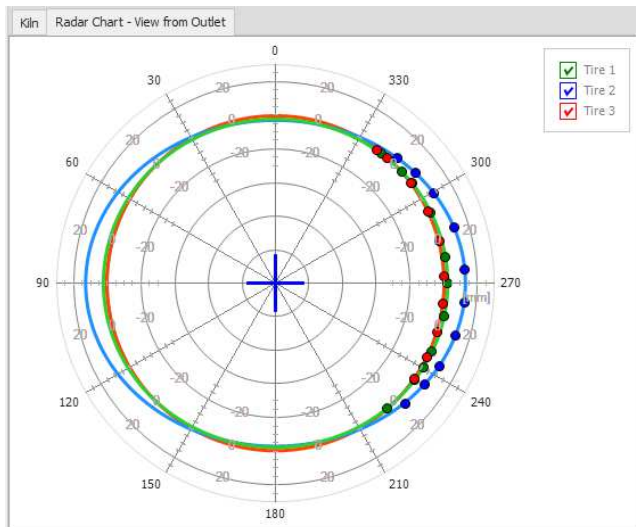

Note:

The tire centers and shape are not precise yet, because the tires are only measured from one side. The insufficient precision is reflected by the “Reliability Number”; it is still zero.

7.5 Verify Station

To double check, if the theodolite or any of the reference points did not move, it is recommended to verify the station. To do so, go to “Measurement / Verify Station”, than the theodolite will measure all the reference points automatically. A popup window will indicate if there is any deviation in the values of the different points.

Fig.7.5.1 (How to verify the station)

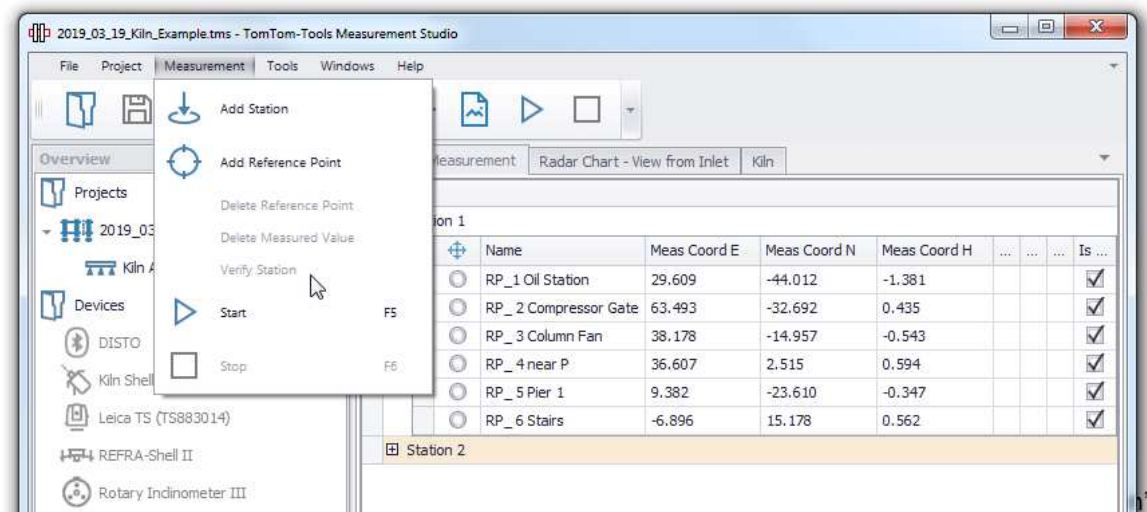

7.6 Relocate the theodolite to Station 2

To reach the required accuracy, the kiln has to be measured from the other side as well.

- Therefore, move the theodolite to the second Station and set it up properly
- Adjust the ball prisms of the Reference Points that they are now directed to the theodolite at Station 2
- Add a new Station in the Measurement Studio by clicking on the button “Add Station”

Fig.7.6.1 (How to add a new Station)

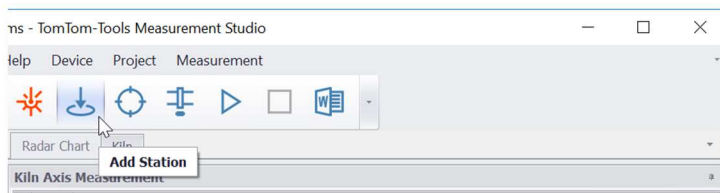

7.7 Measure the Reference Points from Station 2

- Select Station 2
- Select the Reference Point to be measured
- Direct the theodolite towards the selected Reference Point and click the “Start Button”

Fig.7.7.1 (Select Station 2 and the Reference Point to be measured)

Select	Name	Is Selected Target	Name	Meas Coord E	Meas Coord N	Meas Coord H	Transform Error E	Transform Error N	Transform Error H
Station 1									
Station 2									
	RP_1	<input type="radio"/>		1.293	-1.959	0.419	0.000	0.000	0.000
	RP_2	<input checked="" type="radio"/>							
	RP_3	<input type="radio"/>							
	RP_4	<input type="radio"/>							
	RP_5	<input type="radio"/>							

- Verify the precision of the Reference Points when all of them are measured from Station 2.
The deviation which is shown in the list as Transformation Errors should not be greater than 1...2mm per point. Otherwise the respective Reference Point should be disregarded for the merger of the coordinate systems.
- Save the file again (preferable with a new name)

Fig.7.7.2 (Transformation Errors of the Reference Points)

Select	Name	Is Selected Target	Name	Meas Coord E	Meas Coord N	Meas Coord H	Transform Error E	Transform Error N	Transform Error H
Station 1									
	RP_1	<input type="radio"/>		1.361	-2.016	0.418			
	RP_2	<input type="radio"/>		1.218	-5.579	0.751			
	RP_3	<input type="radio"/>		-0.380	-6.226	0.660			
	RP_4	<input type="radio"/>		-2.568	-2.929	1.120			
	RP_5	<input type="radio"/>		-2.951	-0.091	1.305			
Station 2									
	RP_1	<input type="radio"/>		1.293	-1.959	0.419	0.000	0.000	0.000
	RP_2	<input type="radio"/>		0.692	-5.473	0.752	0.000	0.000	0.000
	RP_3	<input type="radio"/>		-0.976	-5.910	0.662	0.000	0.000	0.000
	RP_4	<input type="radio"/>		-2.722	-2.358	1.120	0.000	0.000	0.000
	RP_5	<input checked="" type="radio"/>		-2.737	0.504	1.304	0.000	0.000	0.000

7.8 Measure the tires from Station 2

- Select the tire to be measured in the list
- Measure the points with the help of the target axle as described above
- The values of the tires will appear in the list
- The orange background indicates that the points are measured from the currently selected Station
- The measurement is finished when all tires are measured from both sides

Fig.7.8.1 (complete table with 3 tires measured from both sides)

Kiln Axis															
Tires		Support Rollers		Thrust Rollers		Reference Points		Tire		Tire Clearance		Roller Adjustment Y		Quality	
Name				X [m]	Y [mm]	Z [mm]	Ø [m]	Creep [mm/rev]	Shell Z [mm]	Left [mm]	Right [mm]	Reliability	Coverage [%]		
Tire 1				5.0	0	0	4.902	0	0			10	49		
Points on Tire															
17														<input checked="" type="checkbox"/>	
18														<input checked="" type="checkbox"/>	
19														<input checked="" type="checkbox"/>	
Tire 2				30.5	1	-7	5.087	0	-7	13	11	9	51		
Points on Tire															
01														<input checked="" type="checkbox"/>	
02														<input checked="" type="checkbox"/>	
03														<input checked="" type="checkbox"/>	
04														<input checked="" type="checkbox"/>	
05														<input checked="" type="checkbox"/>	
06														<input checked="" type="checkbox"/>	
07														<input checked="" type="checkbox"/>	
08														<input checked="" type="checkbox"/>	
09														<input checked="" type="checkbox"/>	
10														<input checked="" type="checkbox"/>	
11														<input checked="" type="checkbox"/>	
12														<input checked="" type="checkbox"/>	

7.9 Coverage and Reliability Number (the “Quality” values for each tire)

The **Coverage** shows how much of the tire circumference is covered with measurement points. The higher the percentage the better. Try to get 40% and more.

The **Reliability Number** indicates (from 0...10) the influence on the tire center by each individual point measured on the tire surface.

A 10 shows that the center is very reliable, even when one or the other point would not be measured, the center would still be on the same point.

0: not reliable, 6: sufficient, 7: good, 8...10: very good

The Reliability Number is generated the following way:

A software sequence disables one tire point after the other and checks how much the tire center is changing. The sum of the deviations is deducted from 10.

Example: 16 points are measured on a tire, disabling and enabling a point changes the center by 2mm, $2 \times 10 / 16 = 1.25$ are deducted. Disabling and enabling another point has an impact of 0.5mm, $0.5 \times 10 / 16 = 0.31$ are deducted. The next point changes the center by 1mm, $1 \times 10 / 16 = 0.625$ are deducted and so on, until all tire points are checked.

8 Evaluation of the Results

8.1 Selection of the Anchor Points

The Anchor Points are two points of the kiln axis which are considered as fix and will not be changed. In our example we select the tire 1 at kiln inlet and tire 3 at kiln outlet.

Typically, the drive of the kiln is near the inlet tire; therefore, special attention has to be paid to any corrective moves at the inlet tire because it will affect the gear mesh.

- To select the Anchors, click on the buttons as shown below
- The coordinates of the anchor piers are set to 0.000 in vertical direction (Y) and in horizontal direction (Z)

Fig.8.1.1 (Anchor Selection Window)

Kiln Axis													
Tires			Support Rollers			Thrust Rollers			Reference Points				
Name	📄	📄	Tire				Tire Clearance		Roller Adjustment Y		Quality		
			X [m]	Y [mm]	Z [mm]	Ø [m]	Creep [mm/rev]	Shell Z [mm]	Left [mm]	Right [mm]	Reliability	Coverage [%]	
Tire 1	<input type="radio"/>	<input checked="" type="radio"/>	<input type="radio"/>	5.0	0	0	4.902	0	0			10	49
Tire 2	<input checked="" type="radio"/>	<input type="radio"/>	<input type="radio"/>	30.5	1	-7	5.087	0	-7	➡ 13	11 ←	9	51
Tire 3	<input type="radio"/>	<input type="radio"/>	<input checked="" type="radio"/>	58.4	0	0	5.014	0	0			9	48

8.2 Deviation of the Kiln Axis

The deviations of the tire centers from the straight line between the two Anchor Tires are the results of the Kiln Axis Measurement.

Our example kiln has only 3 tires whereof the middle tire is the one which is deviating from the straight line between the selected Anchor Tires 1 and 3.

The deviation values can be found in the table Fig.7.6.1.

To get a better overview, the tire points can be hidden.

Open the Radar Chart to verify how precisely the measured points are matching with the fitted circle / ellipse.

Fig.8.2.1 (Radar Chart of measured tire points, with fitted circles and tire centers)

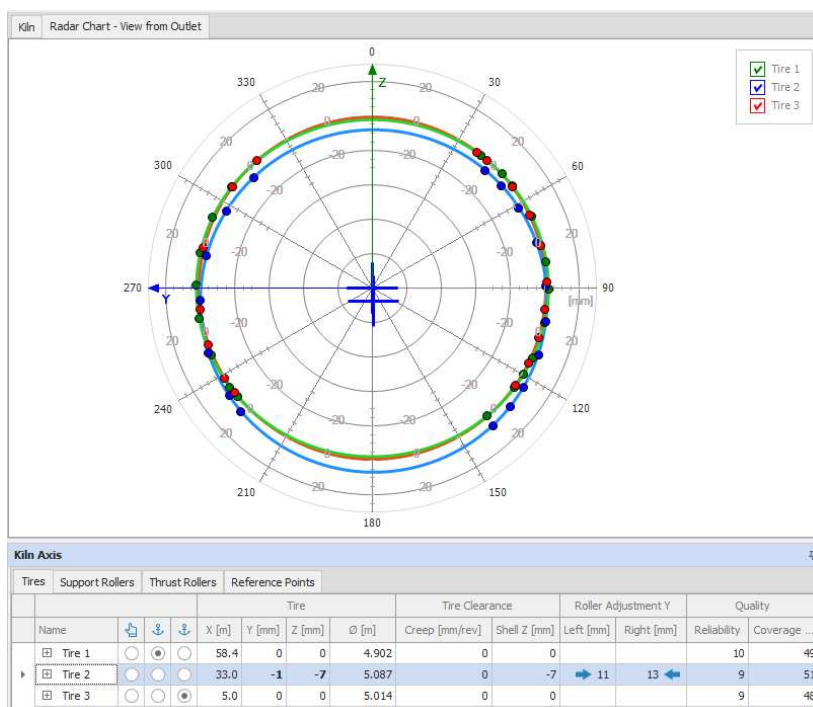

As shown in the table, the tire 2 is 7mm low and 1mm misaligned towards the left side. The coordinate system in the lower left corner is indicating the Y and Z directions which are important for the axis alignment.

- Positive Y-values are indicating that the tire is too high
- Positive Z-values are indicating that the tire is towards the right side (view from zero point, here at outlet)

Fig.8.2.2 (3D view of kiln with coordination system)

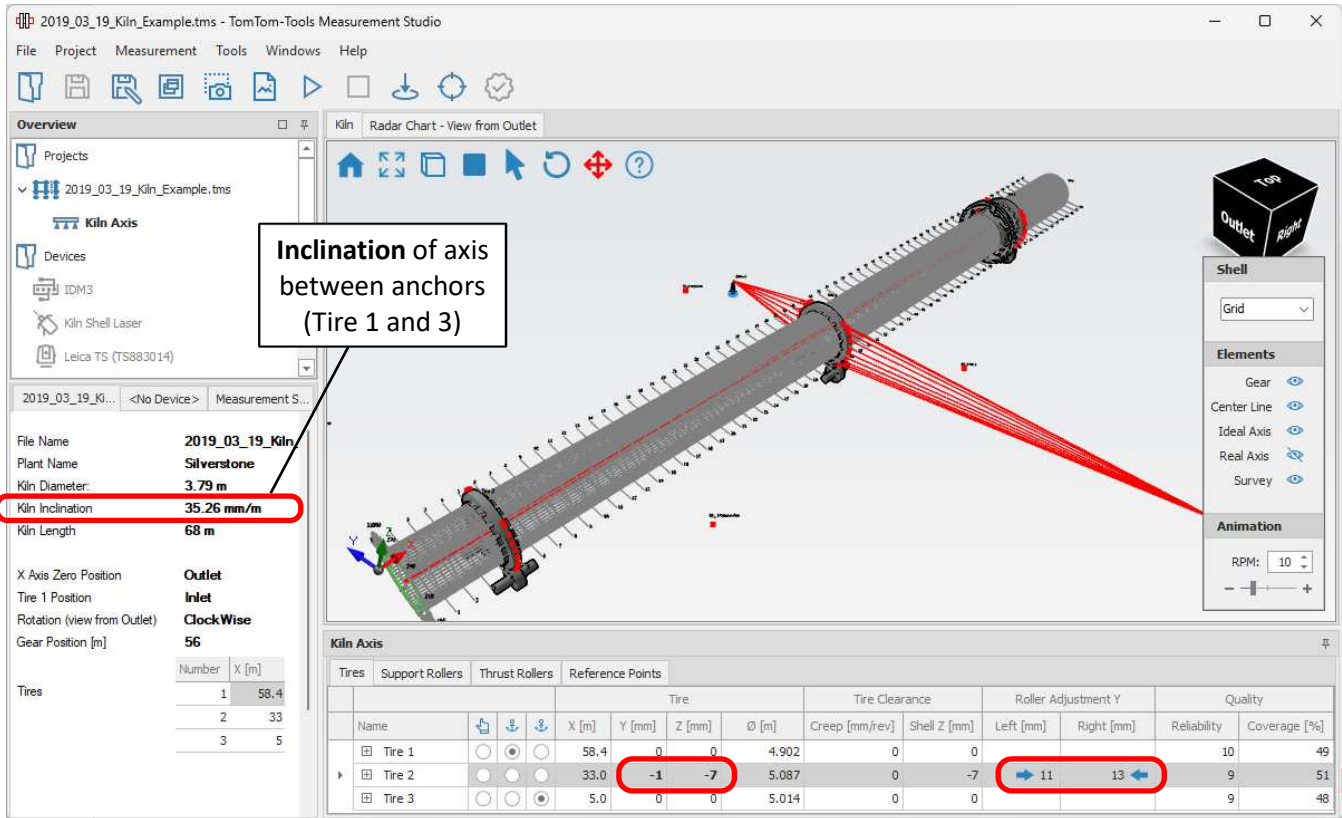

Depending on other aspects on the kiln, different piers might be chosen as anchors. The two main factors to determine the selection of the anchors are

- The gear mesh of the open gear drive
- The kiln inclination

Fig.8.2.3 (other scenario, where tire 2 and 3 are anchors)

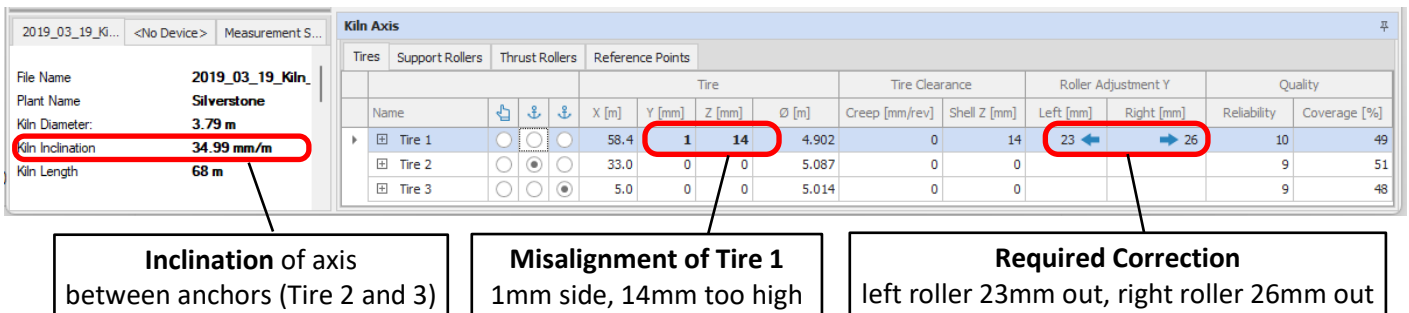

In this example the kiln needs correction by lowering tire 1 by 14mm. The pinion might need to be moved to avoid interference in the gear mesh, but the kiln inclination would come very close to the nominal value of 3.5% or 35mm/m

8.3 Visualisation of the Kiln Axis

The axis deviation is shown in the 3D model.

For better visualization click on the button “orthogonal view”

Fig.8.3.1 (3D view, where tire 2 and 3 are anchors)

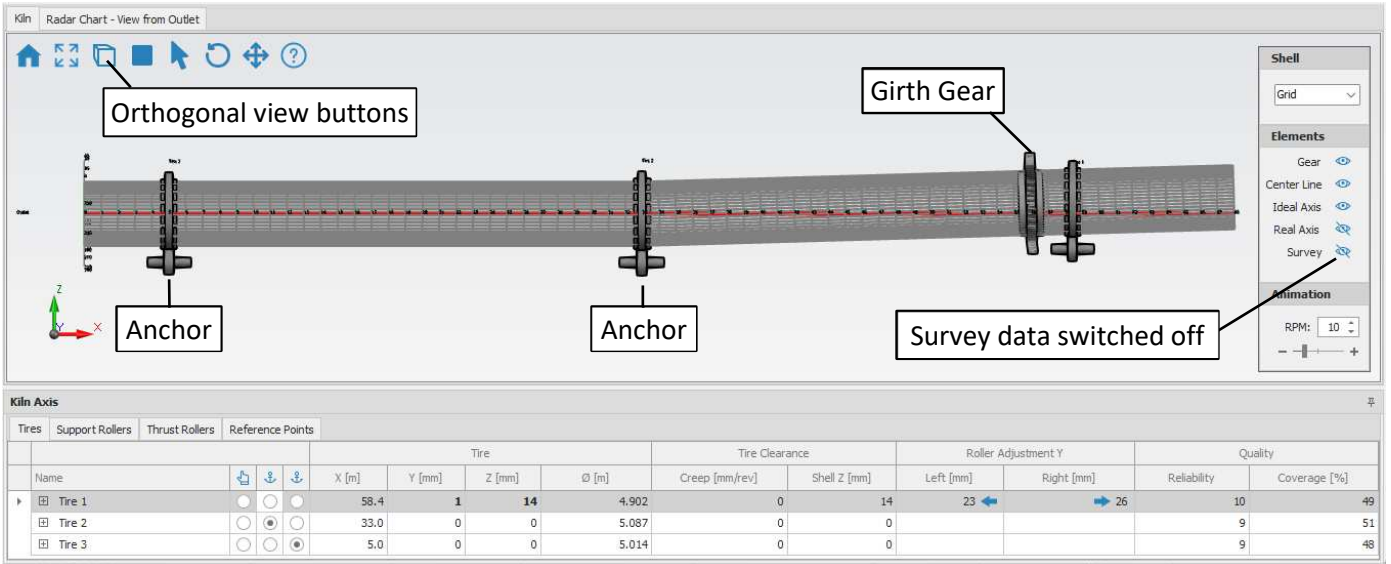

Fig.8.3.2 Radar Chart (where tire 2 and 3 are anchors)

Fig.8.3.3 Radar Chart (where tire 1 and 3 are anchors)

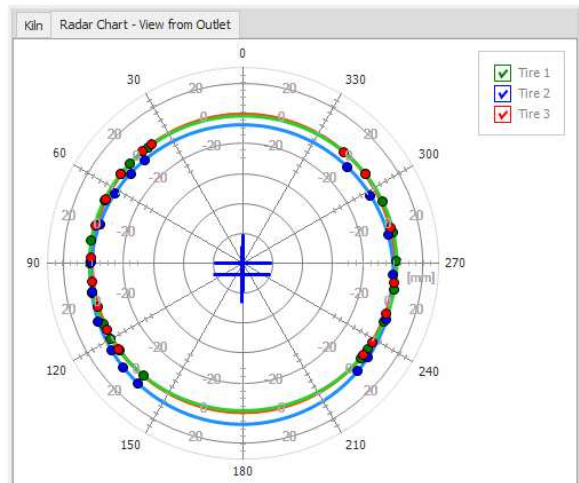
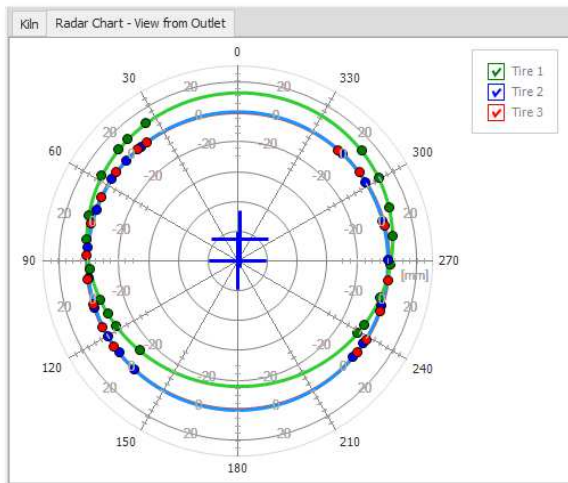
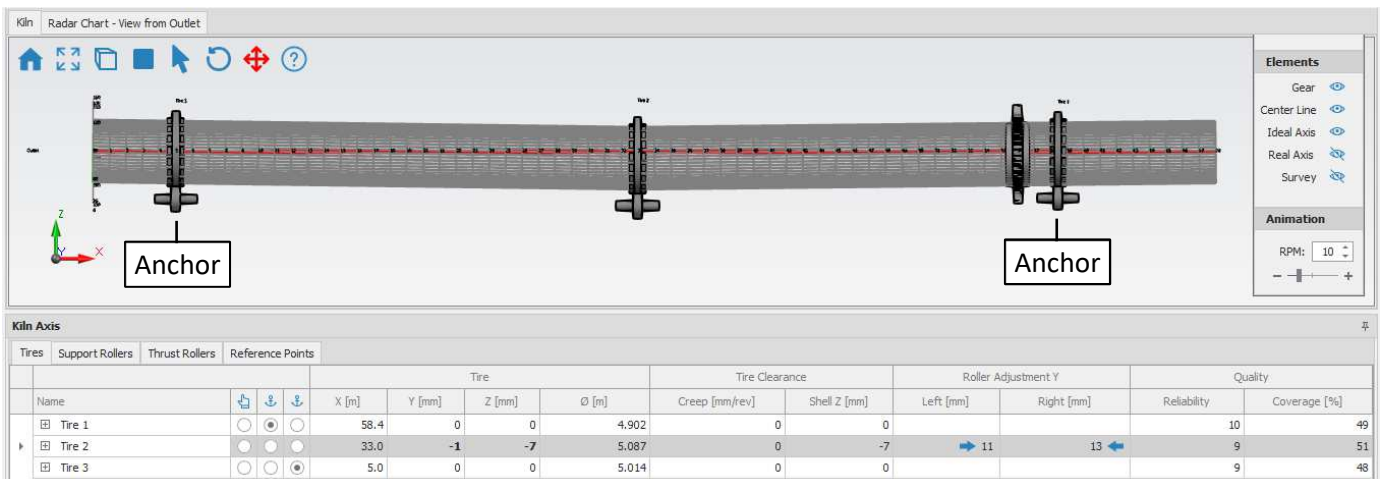

Fig.8.3.4 (3D view, where tire 1 and 3 are anchors)



8.4 Tire Clearance Height Compensation

When the creep of the tires has significant differences, the center height of the kiln axis is affected, therefore it is possible to enter the creep values for compensation. Nevertheless, it is recommended to bring back the tire clearances in acceptable range (10...25mm/rev) instead of only compensating the loss of height by raising the affected tire.

Tire Clearance	
Creep [mm/rev]	Shell Z [mm]
12	0
15	-7
20	0

9 Thrust Roller Alignment Check

The Thrust Rollers are the guide rollers which keep the kiln in position. They restrict the travel in axial direction. To minimize the wear and load on the thrust rollers, they have to be positioned in line with the kiln axis. The position of the thrust rollers can be measured easily and precisely with the Kiln Axis Alignment System during the above described axis measurement.

Note: The Thrust Roller needs to rotate for this measurement.

In case there is no contact with the tire, the roller could be turned manually for this measurement, but the **safety rules must be respected**. (There is no uniform rotation required)

9.1 Position of Theodolite

To measure the alignment of the thrust rollers, the theodolite needs to be located from where the top of the thrust roller and its center is visible. If it is possible to reach the thrust roller from an existing station, as used to measure the tires, then perform the thrust roller measurement as long as the theodolite is still in position.

Maybe it is not possible to reach the thrust roller, so an additional station might be required. Place the theodolite in a position from where not only the center of the thrust roller is visible but also some of the existing reference points (common points) to connect the new station with the previous stations.

9.2 Add a Station

When the theodolite is placed in a new location, from where the thrust roller can be measured, add a new station and direct the reference points towards the theodolite as explained earlier.

Fig.9.2.1 (How to add a new Station)

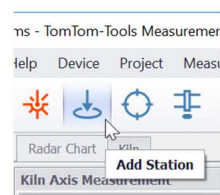

Measure the visible reference points. If you have chosen good locations for them before, you can get now 3...4 of them, which is sufficient.

9.3 If number of Reference Points is not sufficient

Reference points still can be added. It is not the preferred way, adding more Reference Points at a later state, but it is still possible by generating a kind of “chain of stations”. Identify good positions for additional Reference Points, which can be measured from the current station and from, at least, one more station. The additional station is needed to link the new Reference Points with the previous Reference Points, hence you need to measure the new points and some of the previous points from here. This will give the software the possibility to indirectly connect the coordinate system with each other.

9.4 Prepare the Measurement Studio for the Thrust Rollers

Open the settings and add the thrust roller which you like to measure. This kiln is equipped with only one thrust roller on pier 1 (near kiln inlet).

Fig.9.4.1 (How to add a Thrust Roller)

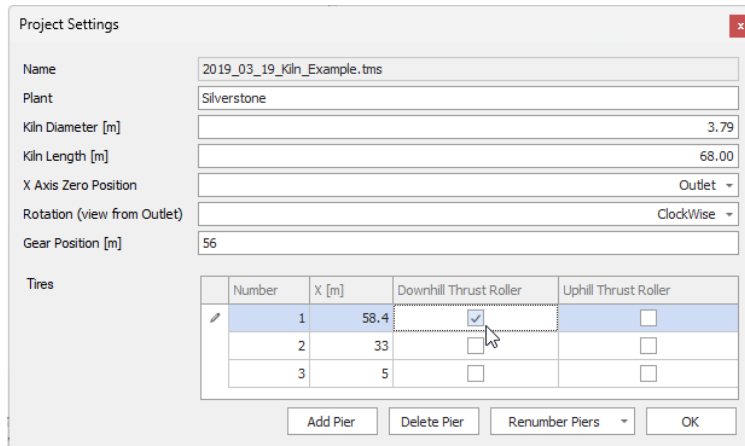

9.5 Placing the 360° Prism

The measurement of the thrust roller center requires a special prism, the 360° Mini Prism GRZ101 with its magnetic base and magnetic knob. It can be measured by the theodolite from all directions except from top or bottom. The 360° Prism has to be placed close to the center of the thrust roller while the roller is rotating as shown in the next pictures.



Attention: For safety reason, never place the prism by hand, always use the Placing Fork together with the Telescopic Pole to reach the roller center.

Fig.9.5.1 “360° Prism” on Placing Fork

Place the prism to the rotating roller in the following way:

1. Attach the Placing Fork to the telescopic pole
2. Tighten the fork and all the stages of the telescopic pole (to be able to apply some torque via the pole)
3. Slide the magnetic mushroom shaped knob onto the fork
Note: The slight magnetic force between the knob and the fork will allow to place the prism safely onto the roller. Nevertheless, hold the telescopic pole horizontal, in order not to lose the prism.
4. Hold the prism tilted in an angle of about 45°, as shown in Fig.9.5.1 and reach the roller center
(tilting the prism reduces the shock impact due to the strong magnetic base)

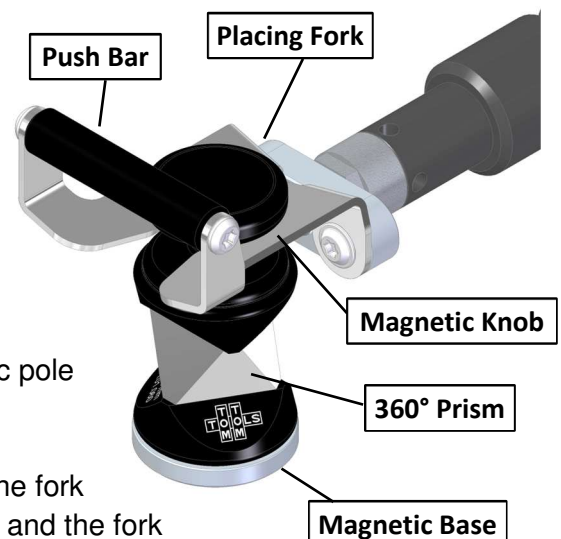

- Place the magnet onto the roller and retract the telescopic pole with the fork
Note: The prism has not to be located exactly in the center of the roller, because the theodolite will follow the circular path of the prism and the Measurement Studio will fit a circle into the measured point from where the center gets calculated. Nevertheless, the closer the prism is circling to the center, the easier it is for the theodolite to track it
- To move the prism closer to the center, flip the Placing Fork and hit slightly the magnetic base with the Push Bar of the fork.
 To see how it works, watch this video:
<https://www.youtube.com/watch?v=GqgbvXkmz4g>

Fig.9.5.2 Placement of the 360° Prism

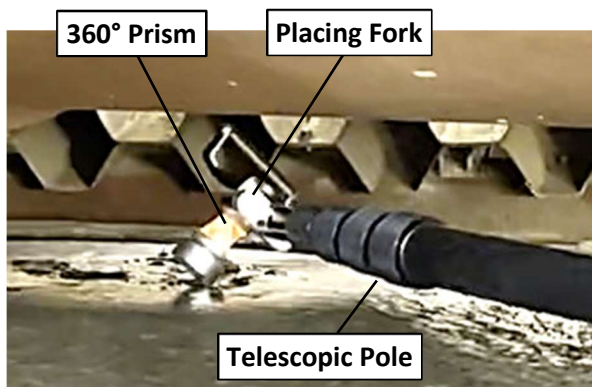
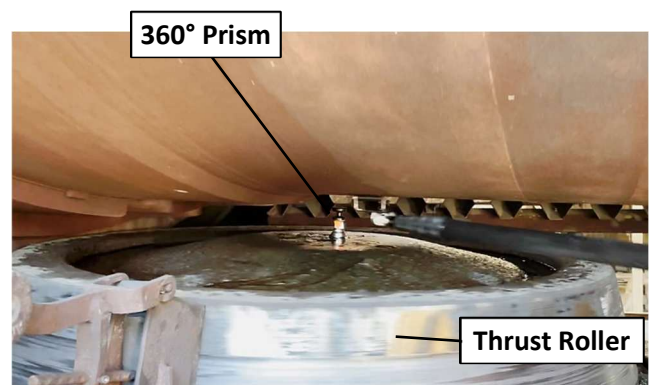
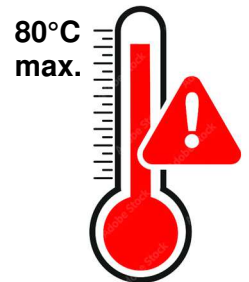

Fig.9.5.3 Prism attached to thrust roller



Attention: The prism should not exceed the maximum temperature of 80°C, otherwise the bonding loses its strength and the prism might fall apart. Keep the exposure to the heat as short as possible, place the prism only when the theodolite is ready to measure and remove it right afterwards.



9.6 Measurement of Thrust Roller Center

- Click on the tab “Thrust Rollers” and select the roller you like to measure.

Fig.9.6.1

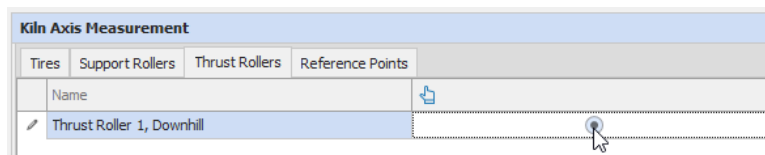

- Aim the 360° prism with the theodolite
 Make sure the theodolite has a free view and there are no obstacles between
 And remember, **the roller must turn**
- Push the “Start” button or [F5]
 The Measurement Studio changes the settings to the 360° prism in the theodolite, which starts searching it. As soon as the prism found, the theodolite locks to the target and starts tracking it. The measured points are recorded and the center of them is calculated, which represents the center of the thrust roller
- As soon as the roller center becomes stable, push the “Stop” button or [F6]
 This measurement typically takes only 5...10 sec.

9.7 Measurement Result

The following example shows that a 3rd Station was required to measure the Thrust Roller and that its center has an offset of 8mm to the kiln axis.

Fig.9.7.1 Results of Thrust Roller position measurement

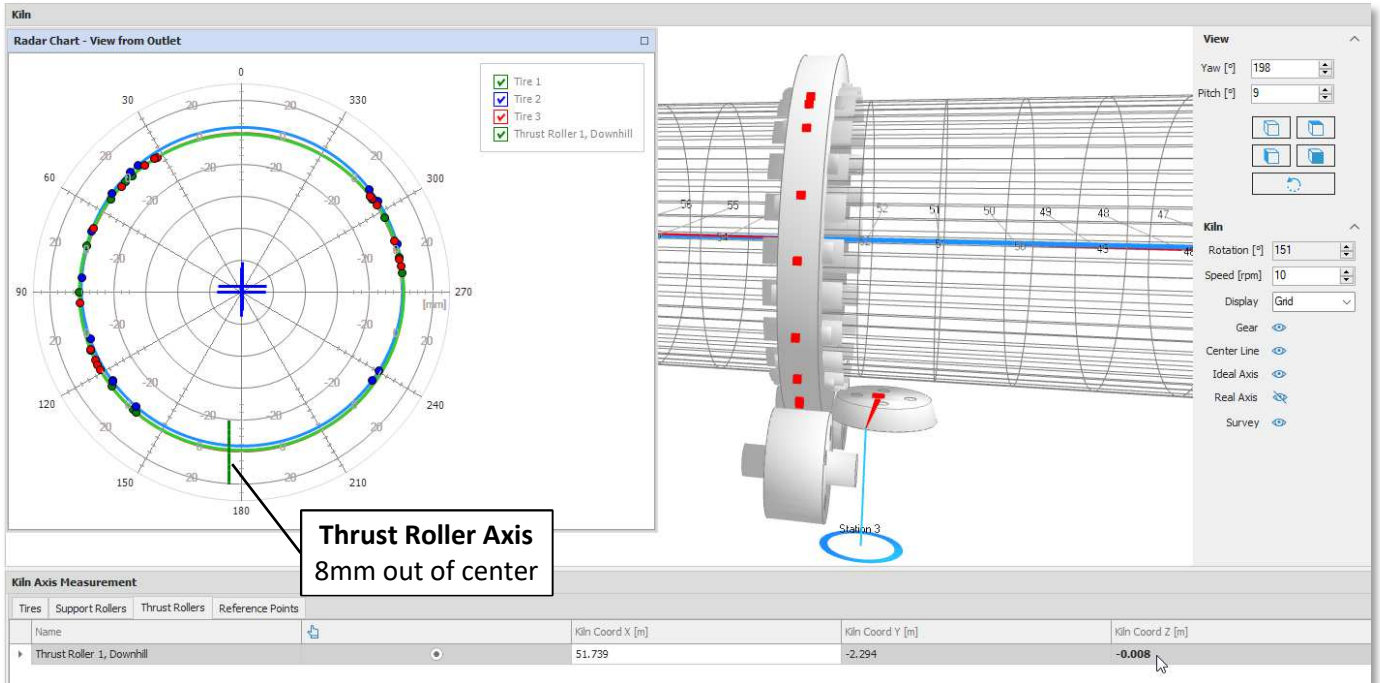
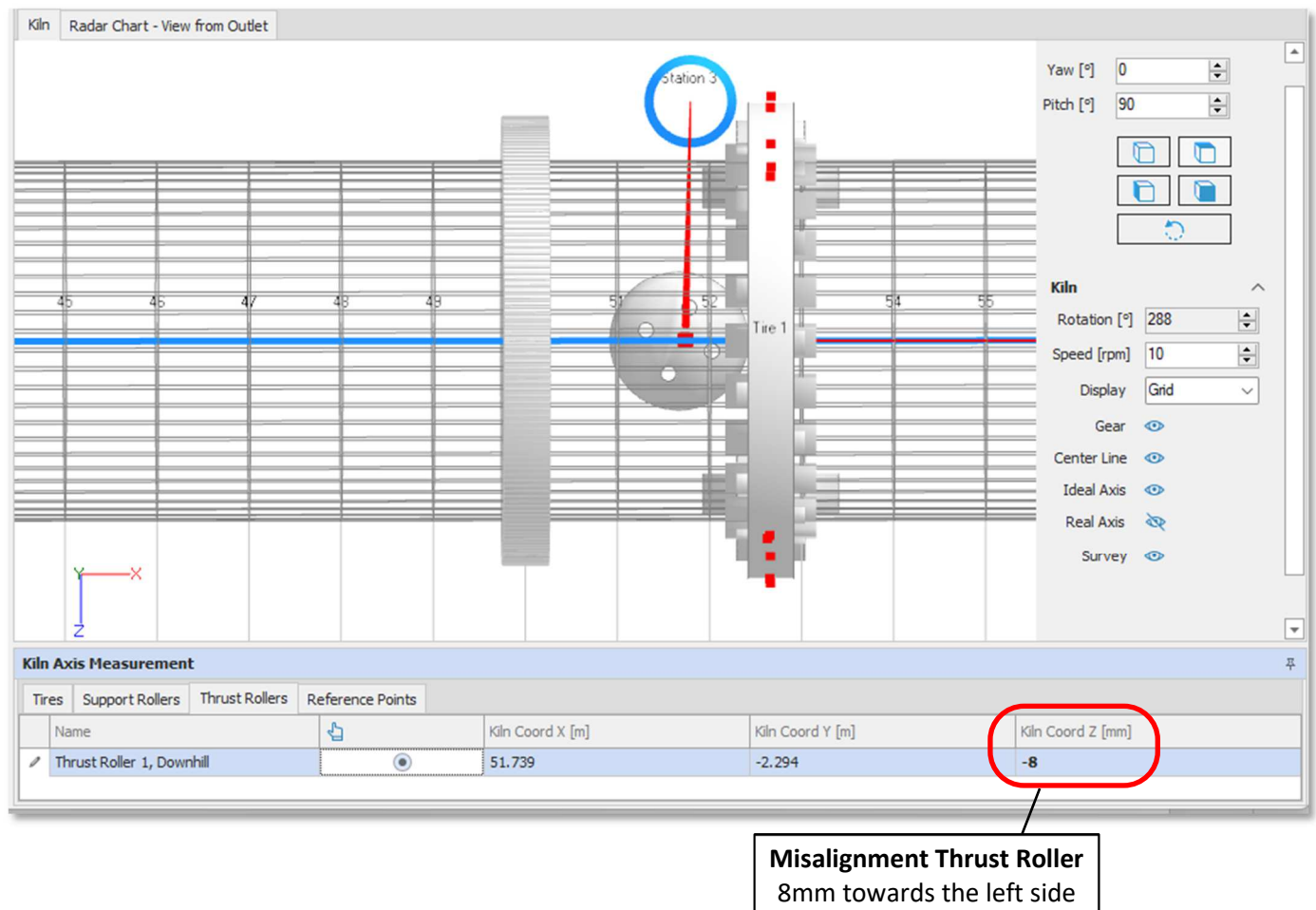

Fig.4.7.2



10 Support Roller Alignment Check

The axis of the different support rollers can be checked by this Kiln Axis Alignment System too, when there is access to the roller shaft via an opening in the bearing housings. Measuring the roller axis is usually not required. It should not be considered as a standard measurement like the kiln axis. The alignment of a roller is normally only measured if the contact between a tire and roller is poor despite a good cylindricity of tire and rollers is given (checked with the Measuring wheel).

The measurement is done by placing a ball prism to each end of the roller shaft. The end of the shaft is usually located inside the bearing housing; hence it has to be extended by the “Shaft Extension” and because the shaft is rotating, the “Rotation Adapter” is needed, which maintains the orientation of the ball prism.

Notes: The Support Rollers need to rotate for this measurement.

Adding a station and more reference points, if needed, is done the same way as described in chapter 9.2 and 9.3.

10.1 Placing the Prisms

1. Open the small side cover of the bearing housing to get access to the end of the rotating roller shaft. Avoid oil contamination.
2. Attach the magnetic Shaft Extension to the roller shaft. In case there is a large bore in the center of the roller shaft, change the position of the magnets to a bigger diameter. Make sure the magnets are tightened properly. Place the Shaft Extension into the center of rotation without high eccentricity, to avoid any contact with the bearing housing.



Attention:

- Do not open covers on the bearing housing, which are made to be opened safely during kiln operation.
- Do not open the large side covers on the bearing housing, there are rotating parts and pinch points behind (e.g. oil scoops).
- Avoid dust and any particles entering the bearing housing while the cover is open
- Be cautious about the rotating parts added to the shaft end (Shaft Extension and Rotation Adapter)

3. Place the Rotation Adapter onto the disk of the Shaft Extension
4. Add the Magnetic Base and the Ball Prism to the Rotation Adapter and direct the prism towards the theodolite

Fig.10.1.1 Shaft Extension with Rotation Adapter

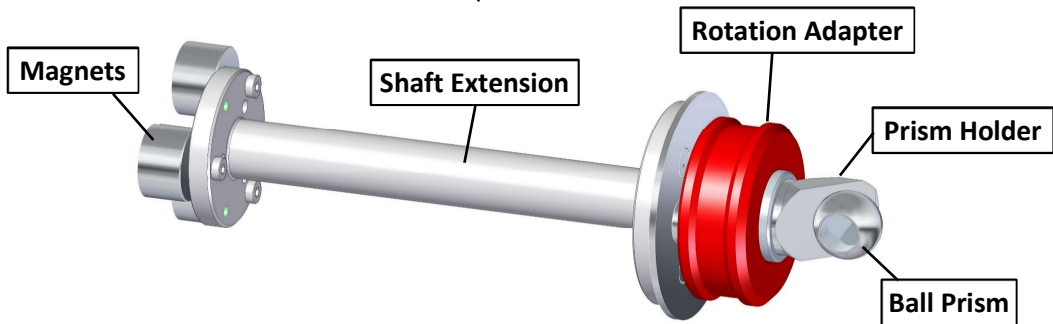
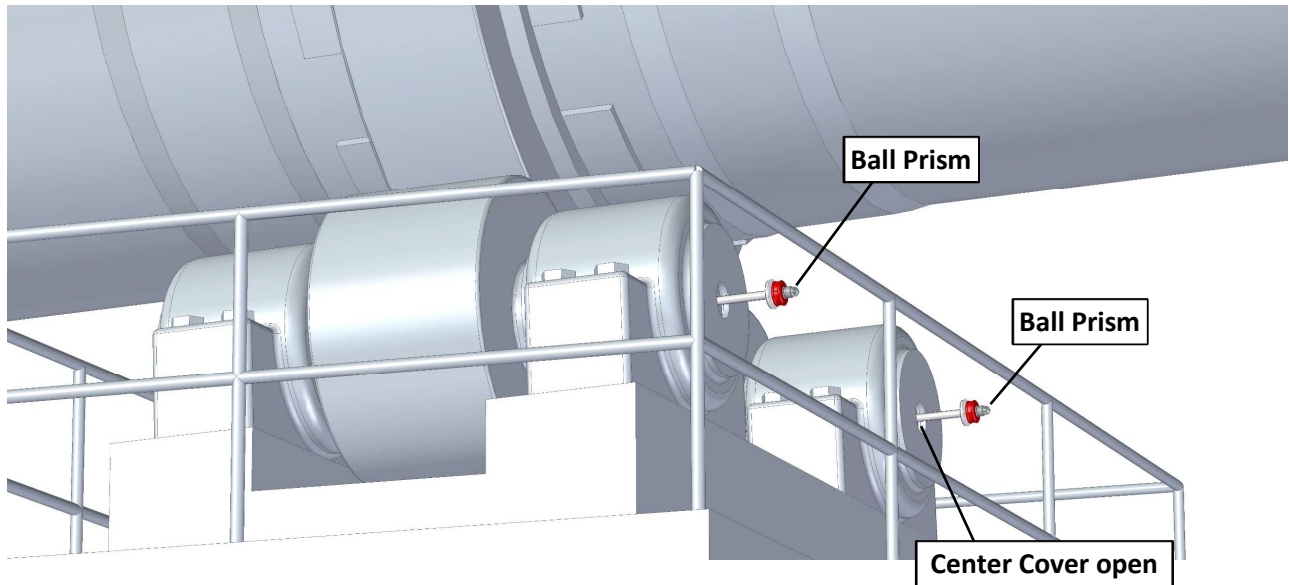

Fig.10.1.1 Ball prisms attached to the roller shafts



Note: The prism has not to be located exactly in the center of rotation, because the theodolite will follow the circular path of the prism and the Measurement Studio will fit a circle into the measured point from where the center gets calculated. Nevertheless, the closer the prism is circling to the center, the easier it is for the theodolite to track it

Fig.10.1.2 Ball prism attached to the roller shaft



10.2 Measurement of Support Roller Axis

1. Click on the tab “Support Rollers” and select the roller you like to measure.
The selected roller will be highlighted as shown in the screenshot below.

Roller	Inclination	Relative Inclination	Skewing																					
Pier 1, Roller Left	35.8 mm/m	0.5 mm/m	-1.6 mm/m																					
Pier 1, Roller Right	24.6 mm/m	-0.7 mm/m	0.7 mm/m																					
<table border="1"> <thead> <tr> <th>Name</th> <th>Survey Coord X [m]</th> <th>Survey Coord Y [m]</th> <th>Survey Coord Z [m]</th> <th>Kiln Coord X [m]</th> <th>Kiln Coord Y [m]</th> <th>Kiln Coord Z [m]</th> </tr> </thead> <tbody> <tr> <td></td> <td>-48.440</td> <td>9.734</td> <td>-1.776</td> <td>48.314</td> <td>-2.870</td> <td>1.655</td> </tr> <tr> <td></td> <td>-46.578</td> <td>9.684</td> <td>-3.808</td> <td>45.558</td> <td>-2.825</td> <td>1.628</td> </tr> </tbody> </table>				Name	Survey Coord X [m]	Survey Coord Y [m]	Survey Coord Z [m]	Kiln Coord X [m]	Kiln Coord Y [m]	Kiln Coord Z [m]		-48.440	9.734	-1.776	48.314	-2.870	1.655		-46.578	9.684	-3.808	45.558	-2.825	1.628
Name	Survey Coord X [m]	Survey Coord Y [m]	Survey Coord Z [m]	Kiln Coord X [m]	Kiln Coord Y [m]	Kiln Coord Z [m]																		
	-48.440	9.734	-1.776	48.314	-2.870	1.655																		
	-46.578	9.684	-3.808	45.558	-2.825	1.628																		
Pier 2, Roller Left	35.5 mm/m	0.2 mm/m	0.6 mm/m																					
Pier 2, Roller Right	35.7 mm/m	0.5 mm/m	0.2 mm/m																					
Pier 3, Roller Left	36.2 mm/m	0.9 mm/m	-0.4 mm/m																					
Pier 3, Roller Right	34.7 mm/m	-0.5 mm/m	-0.3 mm/m																					

2. Aim the ball prism with the theodolite
Make sure the theodolite has a free view and there are no obstacles between
And remember, **the roller must turn**
3. Push the “Start” button or [F5]
The theodolite starts searching the prism, locks to the target and starts tracking it.
The measured points are recorded and the center of them is calculated, which represents one side of the roller axis
4. As soon as the roller center becomes stable, push the “Stop” button or [F6]
This measurement typically takes only 5...10 sec.
5. Remove the Shaft Extension with the prism and close the bearing housing

The alignment of the roller shaft is only known when it is measured at both sides. To measure the shaft on the other side, usually the theodolite needs to be relocated, hence another Station is required.

11 Components and Dimensions

11.1 Target Axle

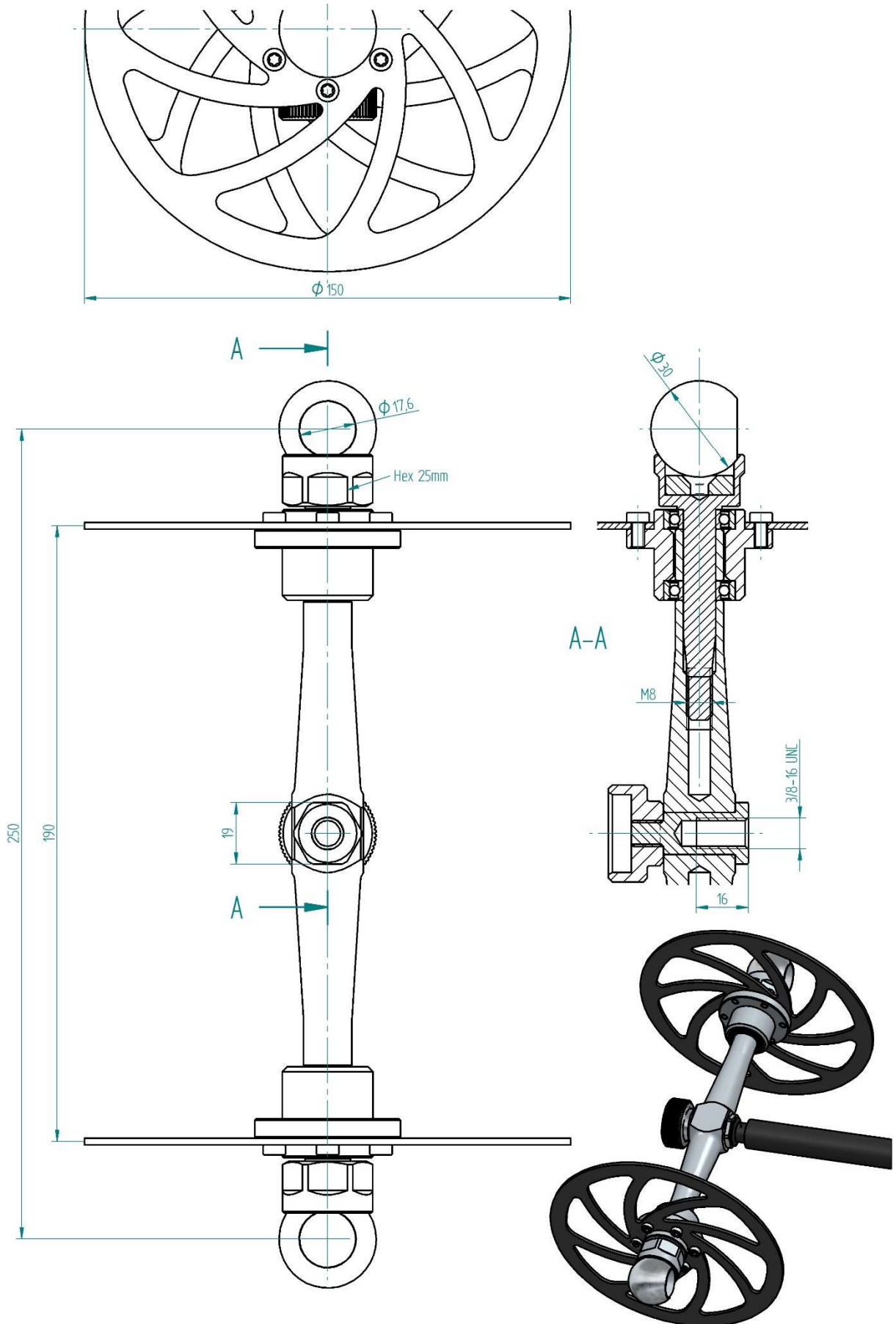

11.2 Ball Swivel

To be mounted optionally between the Telescopic Pole and the Target Axle, when straight access to the tire is not given (e.g. below tire at 6 o'clock position)

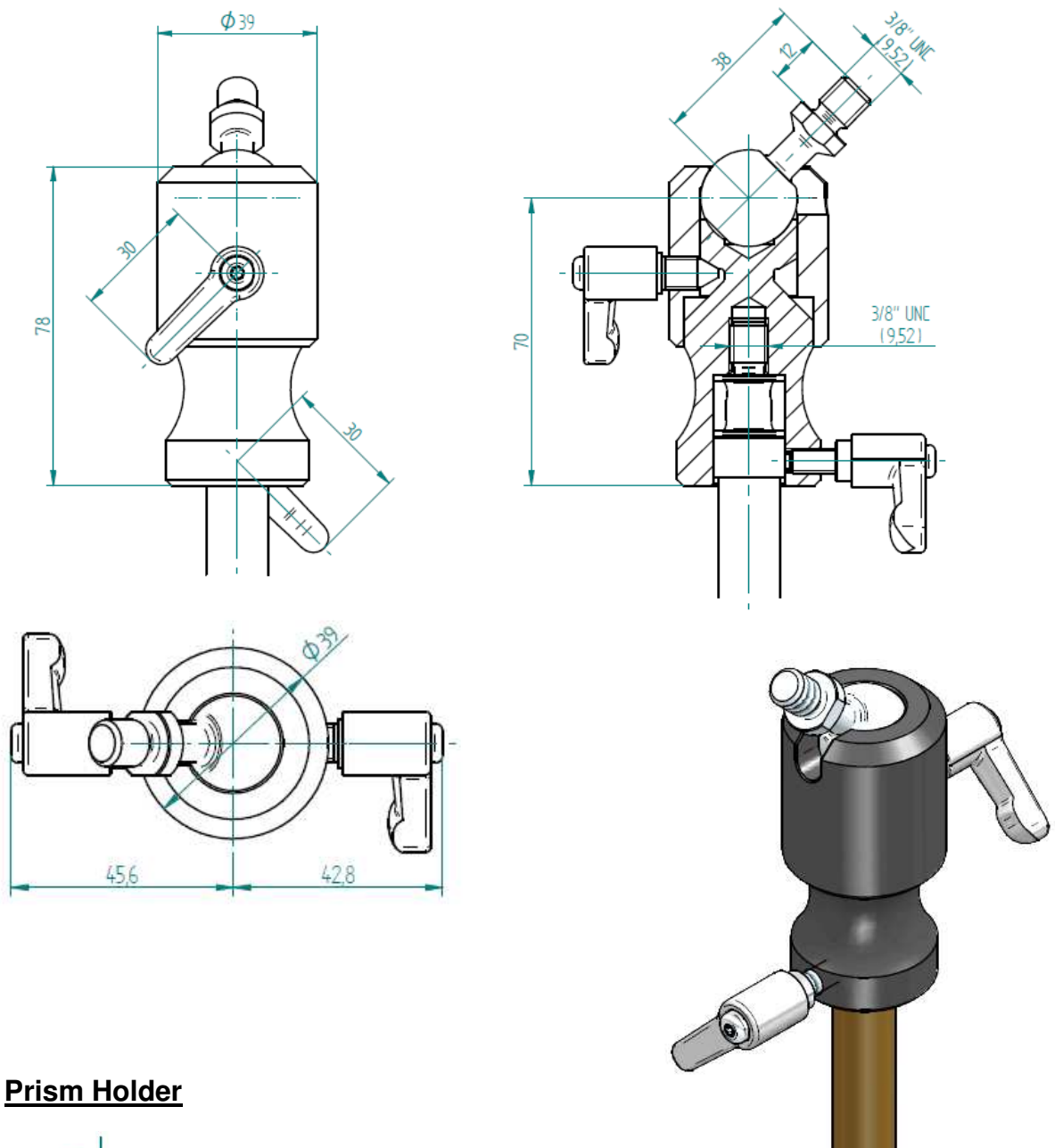

11.3 Prism Holder

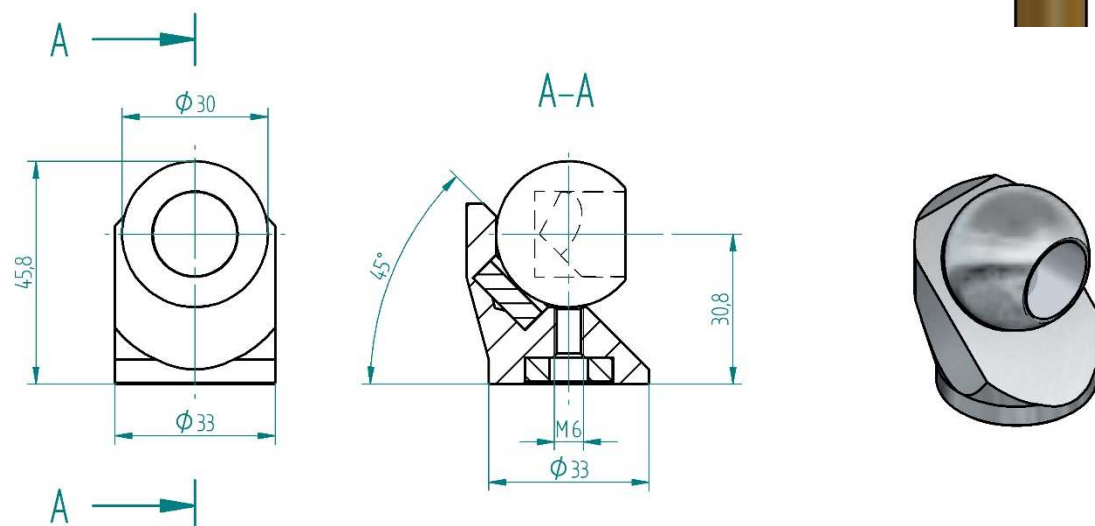

11.4 Base Magnet

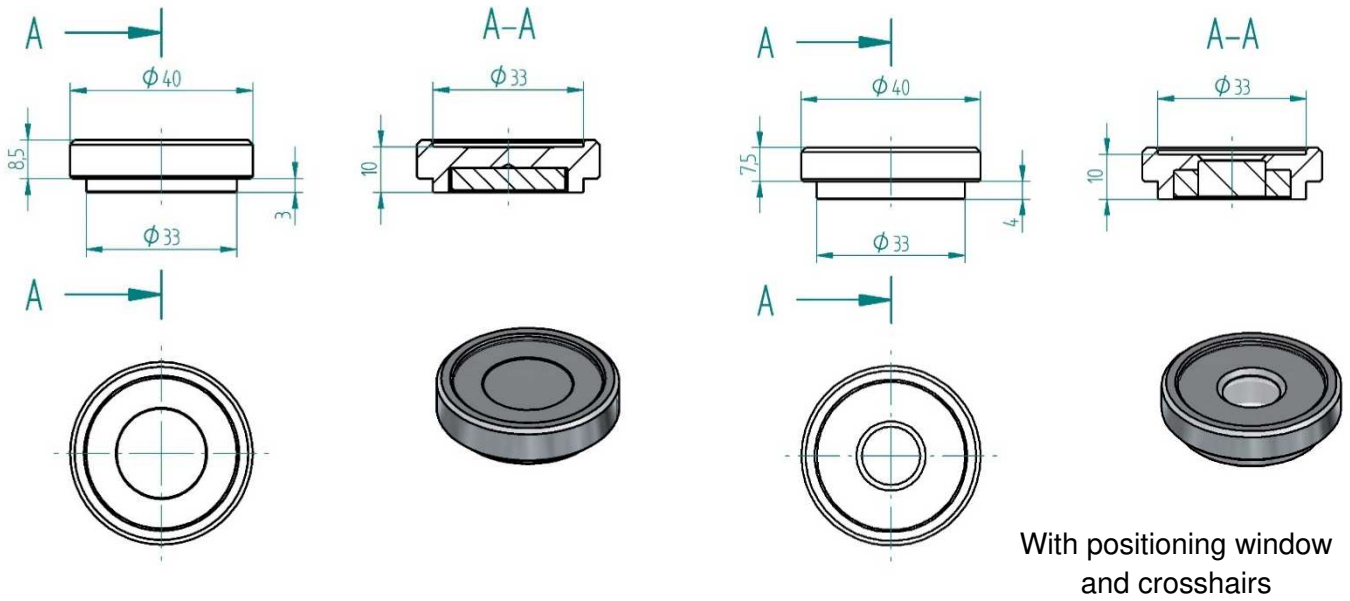

11.5 Base Disk

These disks are made from stainless steel for permanent mounting. They can be bolted with a countersunk screw or with the M8 thread to steel or concrete structures.

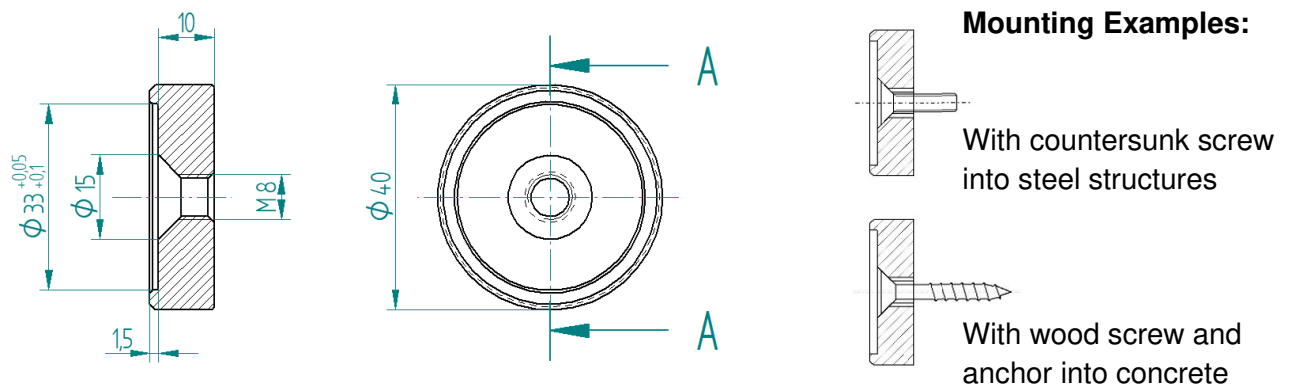

11.6 360° Prism

360° Prism assembly
KAA.01.060

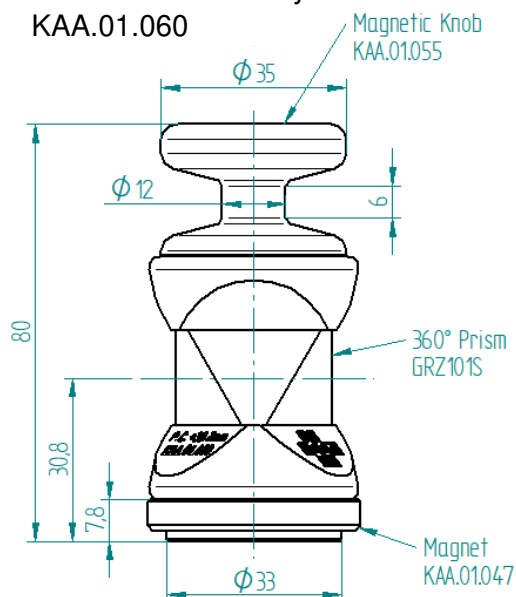

Placing Fork
KAA.01.050



11.7 Rotation Adapter

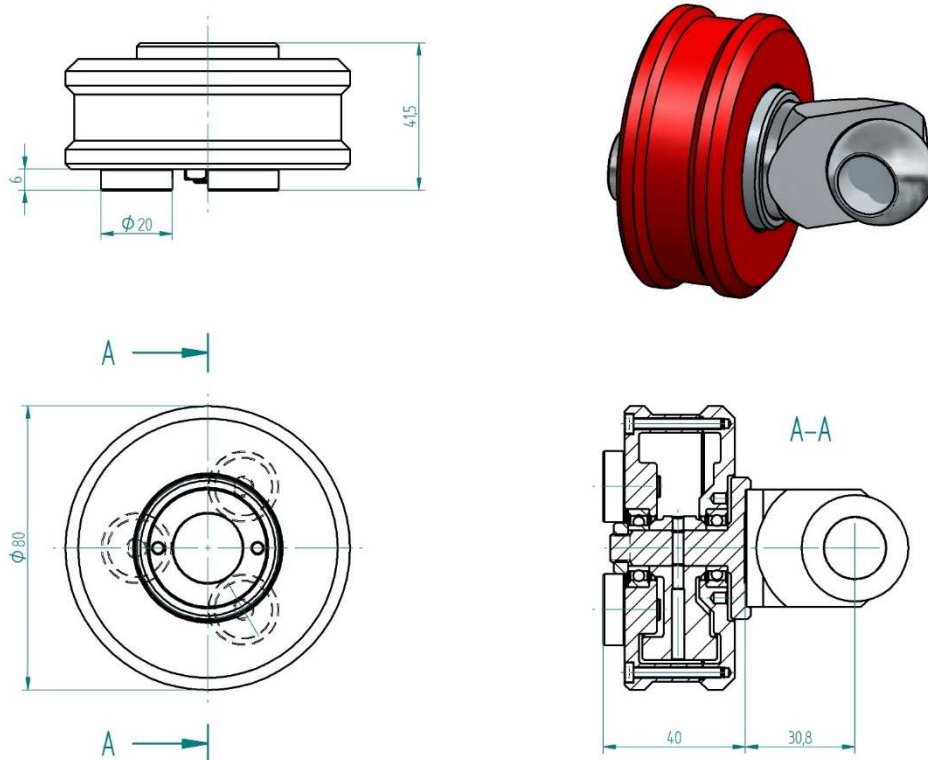

11.8 Shaft Center Adapter

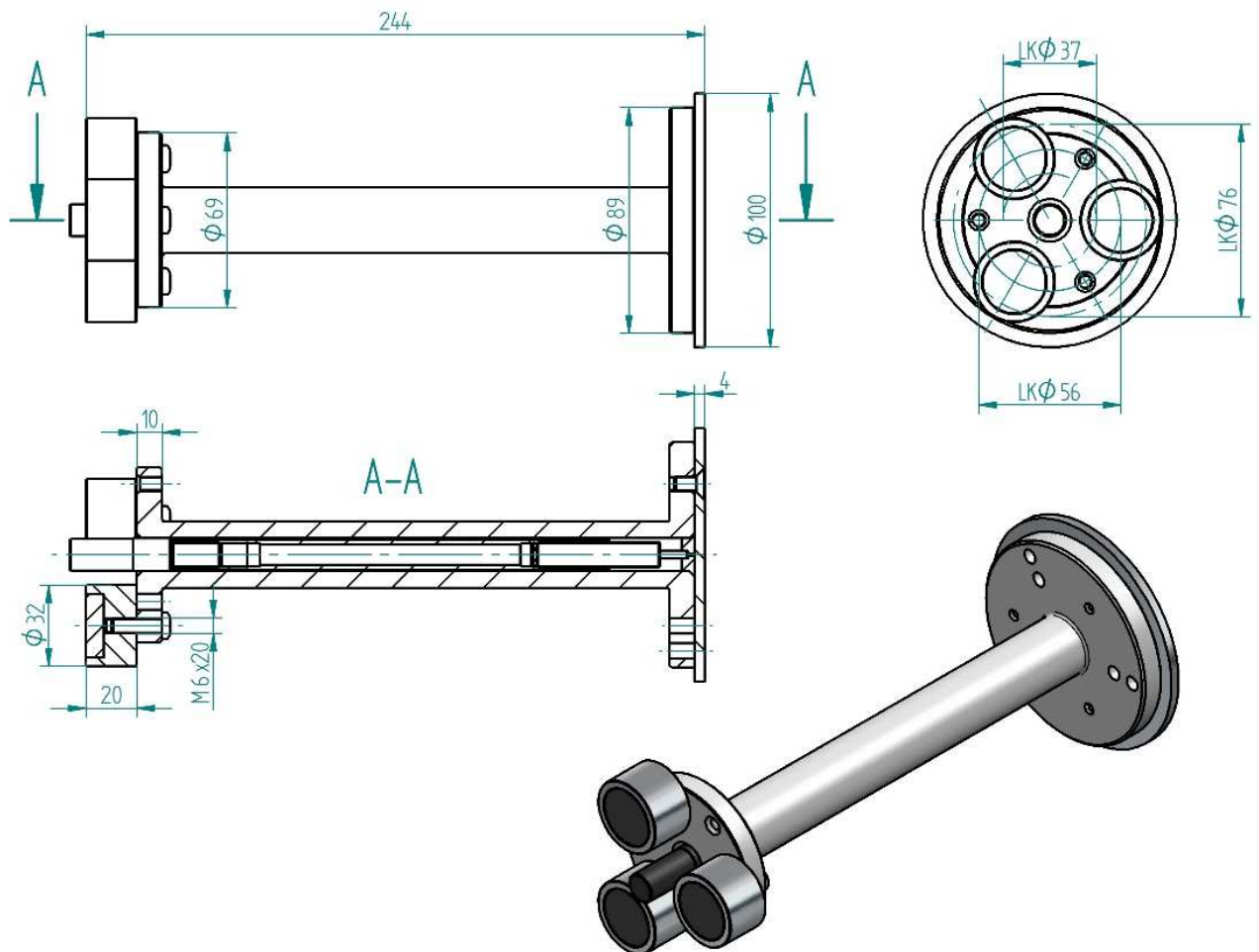

12 List of Components

The following items are included in the Kiln Axis Alignment Kit:

	Item Name	Pieces
1	Transport case with foam cushioning Peli 1555 Air, 63 x 40 x 21cm, black	1
2	Target Axle with magnetic target holders for target ball diameter 30mm, wheel diameter 150mm	1
3	Shaft Center Adapter with heat resistant magnets	2
4	Allen Key 4mm for Shaft Center Adapter	1
5	Rotation Adapter for target holders	2
6	Prism Holder 45° design, height 30.8mm, for ball diameter 30mm	10
7	Ball Target diameter 30mm with triple prism (stainless steel) prism constant: -11.3mm (Leica: +23,1mm)	12
8	Base Magnet diameter 33mm, height 10mm, magnetic force ~400N	8
9	Base Magnet with positioning window and crosshairs diameter 33mm, height 10mm, magnetic force ~300N	2
10	Base Disk diameter 33mm, height 10mm, for permanent installation	10
11	360° Prism with magnetic knob to measure the center of thrust rollers prism constant: -3.7mm (Leica: +30.7mm)	1
12	Placing Fork to be mounted on the telescopic pole, to place the 360°Prism	1
13	Protective radio intercom headset (3M Peltor, helmet mount)	2
14	Battery pack for Headset	4
15	Battery charger for Headset including USB cable	2
16	Power adapter (100-240 VAC), with double USB output	1
17	Long range USB Bluetooth adapter , Sena Parani UD100	1
18	USB flash drive with software and manual	1
19	Telescopic Pole (long) for target axle (made of high strength carbon fiber tubes) lengths: retracted: 155cm, fully extended: 637cm	1
20	Telescopic Pole (short) for target axle (made of high strength carbon fiber tubes) lengths: retracted: 120cm, fully extended: 462cm	optional
21	Ball Swivel to be placed between Telescopic Pole and Target Axle (optionally, only needed when straight access to tire is not given)	1
22	Protection tube casing for Telescopic Pole, length: 163cm, diameter 6cm	1
23	Transport bag for Telescopic Pole (with sufficient space to accommodate the tripod from the theodolite as well)	1
24	Industrial 10.1" Tablet PC (Panasonic FZ-G2) with pre-installed software, integrated Long Range Bluetooth transport bundle and large battery pack	1
25	Charger for Tablet PC (100-240 VAC),	1
26	Industrial Key Board for Tablet PC (English)	1