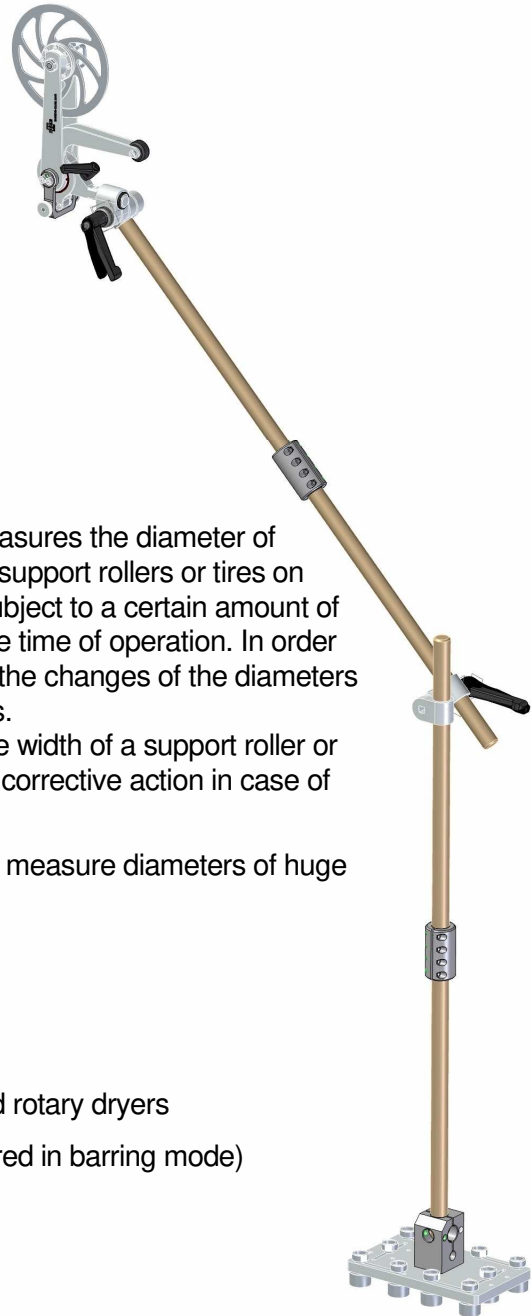


# Measuring Wheel



## 1. INTRODUCTION:

The Measuring Wheel is a measurement tool, which measures the diameter of slow rotating cylinders during operation; for example on support rollers or tires on rotary kilns or dryers. These components are typically subject to a certain amount of wear and have to be re-machined or replaced after some time of operation. In order to keep the kiln or drier axis aligned; it is essential to know the changes of the diameters and to compensate them by adjusting the roller positions.

By measuring the diameter at various positions along the width of a support roller or tire, its cylindricity gets known, which helps to define the corrective action in case of deviations.

The Measuring Wheel can be considered as a caliper to measure diameters of huge rotating cylinders.

### Typical applications:

Diameter measurement of:

- Support rollers, tires and shell on rotary kilns and rotary dryers
- Trunnions or tires and shell on ball mills (measured in barring mode)

### 1.1 Safety:

Rotary kilns, dryers and mills, where this tool typically is used, are huge rotating equipment with many pinch points, they can cause serious injuries. Therefore only specialized and trained personnel shall work close to these machines. To use the tool, follow strictly the local safety rules given by the respective plant / factory / local authorities and discuss the application with the safety engineer in charge.

The tools provided by TomTom-Tools GmbH have proven their functionality in various applications; nevertheless TomTom-Tools GmbH does not take any responsibility for the application on site regarding safety. The plant is responsible for the safety, according to the local law, in a way that nobody can be hurt or injured. The application and safety instructions below are guidelines and not exhausted which include the experience from previous measurement campaigns and might need to be adapted to the local safety requirements.

**TABLE OF CONTENT**

<b>1.</b>	<b>Introduction:</b> .....	<b>1</b>
1.1	Safety:.....	1
1.2	Measuring Principle: .....	4
1.3	Tool Kit includes:.....	6
<b>2.</b>	<b>Main Components</b> .....	<b>7</b>
2.1	Short Support:.....	7
2.2	Long Support: .....	7
2.3	Wheel Controller: .....	8
2.4	Light Barrier Sensor:.....	8
<b>3.</b>	<b>Installation of the Tool:</b> .....	<b>10</b>
3.1	Place the Light Barrier Sensor .....	10
3.2	Place the Measuring Wheel.....	11
3.3	Connect the electrical cables .....	13
<b>4.</b>	<b>Take Measurement</b> .....	<b>13</b>
<b>5.</b>	<b>Transfer Measurement Results to Computer</b> .....	<b>14</b>
5.1	Software Installation:.....	14
5.2	Bluetooth Adapter .....	14
5.3	Connect the Device with the Laptop.....	15
<b>6.</b>	<b>Take Measurements with Computer</b> .....	<b>16</b>
6.1	Set Up the Measurement Window.....	16
6.2	Start Measurements .....	17
6.3	Export to Excel.....	18
6.4	Create a report.....	18
<b>7.</b>	<b>Main Dimensions</b> .....	<b>19</b>
7.1	Short Support.....	19
7.2	Long Support .....	20

## Caution:



### Pinch Points:

Do not put your hands nor any items close or into pinch points (e.g. girth gear / pinion, kiln tires / support rollers,...)

Keep safe distance to avoid getting caught by moving parts.

**Never place the Measuring Wheel on the side of the pinch point between support roller and tire** ; place it always on the out running side, to avoid the items get caught between



### Magnet Fields:

Be aware of the strong magnet field of the magnet stands.

Keep the tool away from people with pace makers or any other sensitive item as credit cards or magnetic data carrier.



### Clamping:

Do not put fingers between the magnets and magnetic surface. There is the risk for clamping or pinching, due to the strong magnetic force.



### Gloves:

Wear proper gloves to protect your hands from hot and rough surfaces and sharp edges.



### Hot Surface:

After using the tool, some components might be very hot; especially the switch flag and the light barrier sensor

Let them cool down before stowage. Otherwise the box may get damaged.



### Radio Waves:

Be aware of the radio waves (Bluetooth) which are emitted from the tool as well from the Bluetooth adapter on the computer.

Do not keep the tool unnecessary in operation; switch it off, after usage.

**1.2 Measuring Principle:**

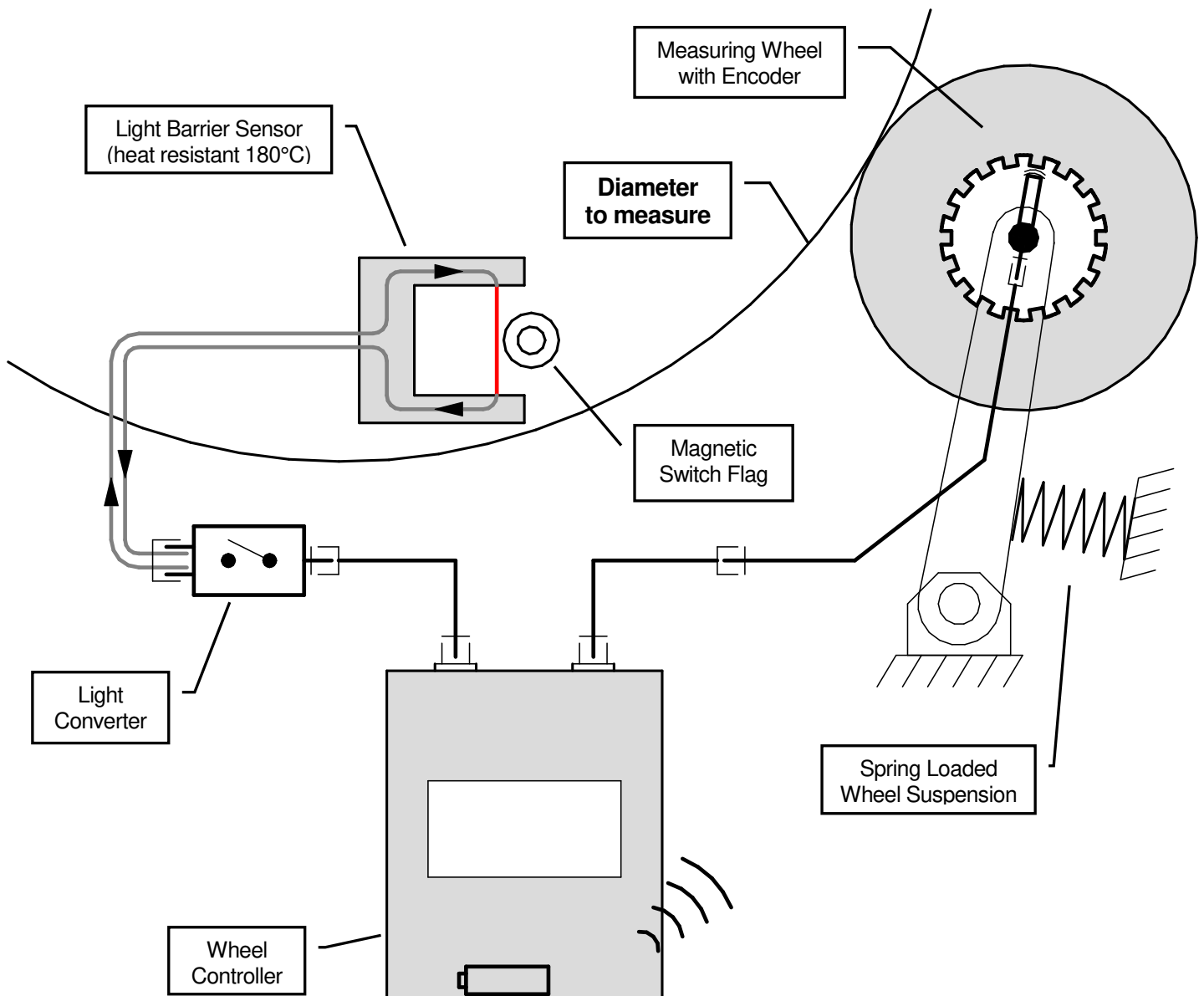
The Measuring Wheel kit consists of three main components, the wheel itself with the integrated rotation encoder, the heat resistant light barrier sensor to indicate the rotation of the item to be measured and the controller which calculates and displays the diameter.

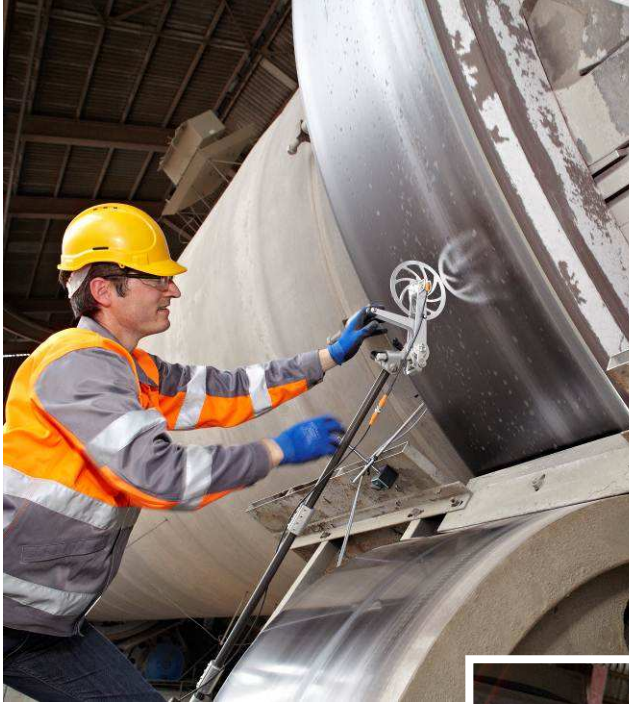
The wheel with the diameter of 176mm is running without slippage on the surface to be measured (e.g. support roller). During each wheel revolution 1760 electrical impulse are sent to the Wheel Controller which is counting them.

With the help of a magnetic switch flag attached to the side face of the support roller or tire, the light barrier sensor provides each revolution an electrical impulse to the Wheel Controller. This revolution impulse starts the counting of the impulses coming from the wheel encoder. After one revolution of the support roller or tire, a new impulse from the barrier sensor is stopping the counting, the diameter value is displayed and immediately the next measuring cycle is started.

With each revolution the diameter value is refreshed whereupon the last reading appears at the lowest of the three rows in the display. The second and the third row show the previous readings.

**a) Schematic with Light Barrier Sensor (standard)**





Measurement of kiln tire diameter



Measurement of support roller diameter



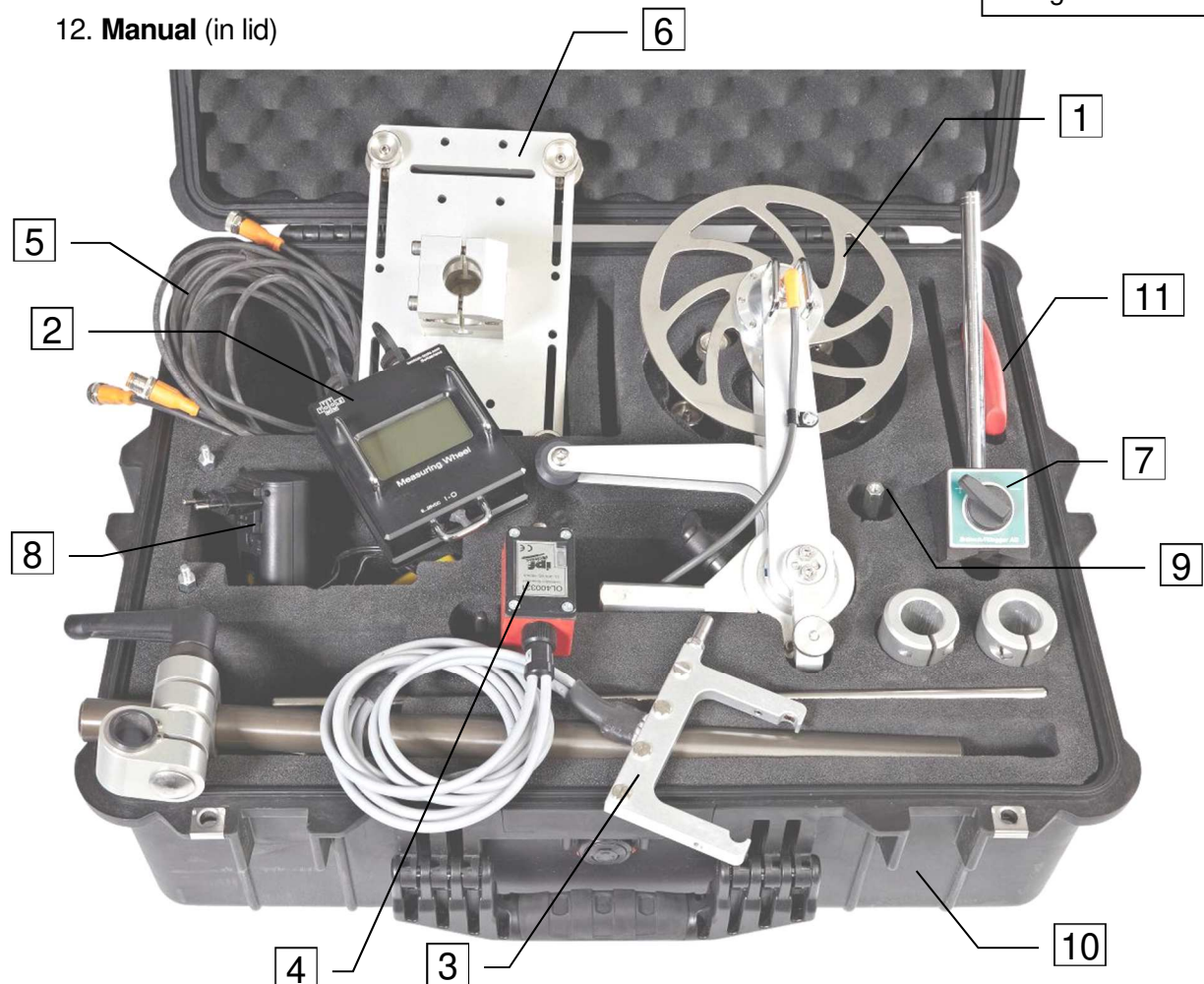
**1.3 Tool Kit includes:**

The Measuring Wheel is coming as a tool kit in a strong and tight transport case, which includes the following items:

1. **Measuring Wheel** with integrated rotation encoder and spring loaded wheel suspension
2. **Wheel Controller** with graphic display
3. **Light Barrier Sensor** with opening 80mm, heat resistant up to 180°C
4. **Light Converter** for Light Barrier Sensor
5. **Sensor Cables** with 2 and 5m length
6. **Magnetic Stand** for Measuring Wheel  
Including base plate with 8 magnets, connectors and 4 extension rods
7. **Magnetic Stand** for Light Barrier Sensor  
Including magnetic base, connectors and extension rod
8. **Battery Charger** with different plug adapters (100...240VAC)
9. **Magnetic switch flag** with heat resistant magnet (up to 300°C) and extension rods
10. **Transport Case** with foam cushioning, extra tough, water and dust seal (suitable for air cargo)
11. **Allen Key** for assembly
12. **Manual** (in lid)



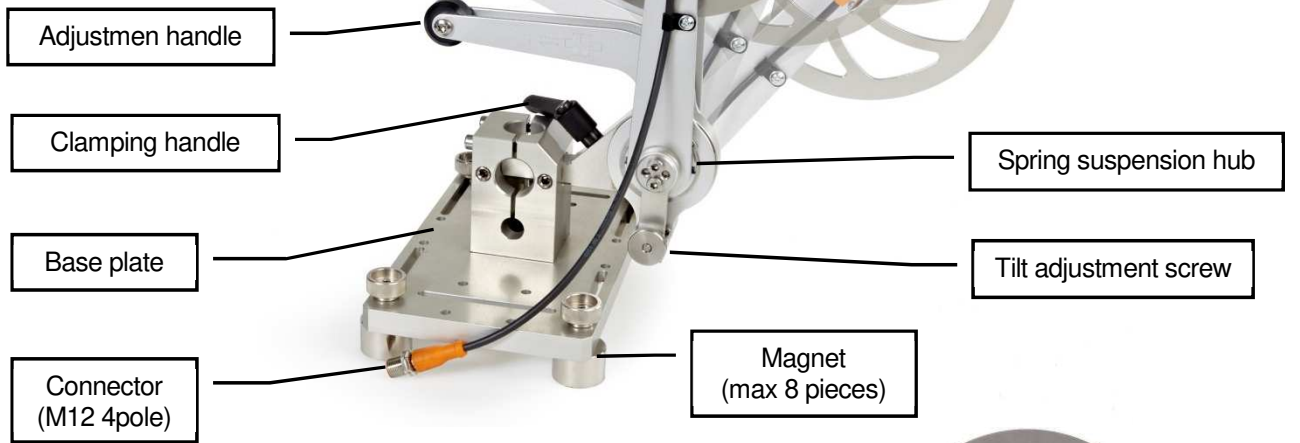
**Transport Case**  
Type: Explorer 5823  
67x51x26.2cm  
Weight total: 24kg



## 2. MAIN COMPONENTS

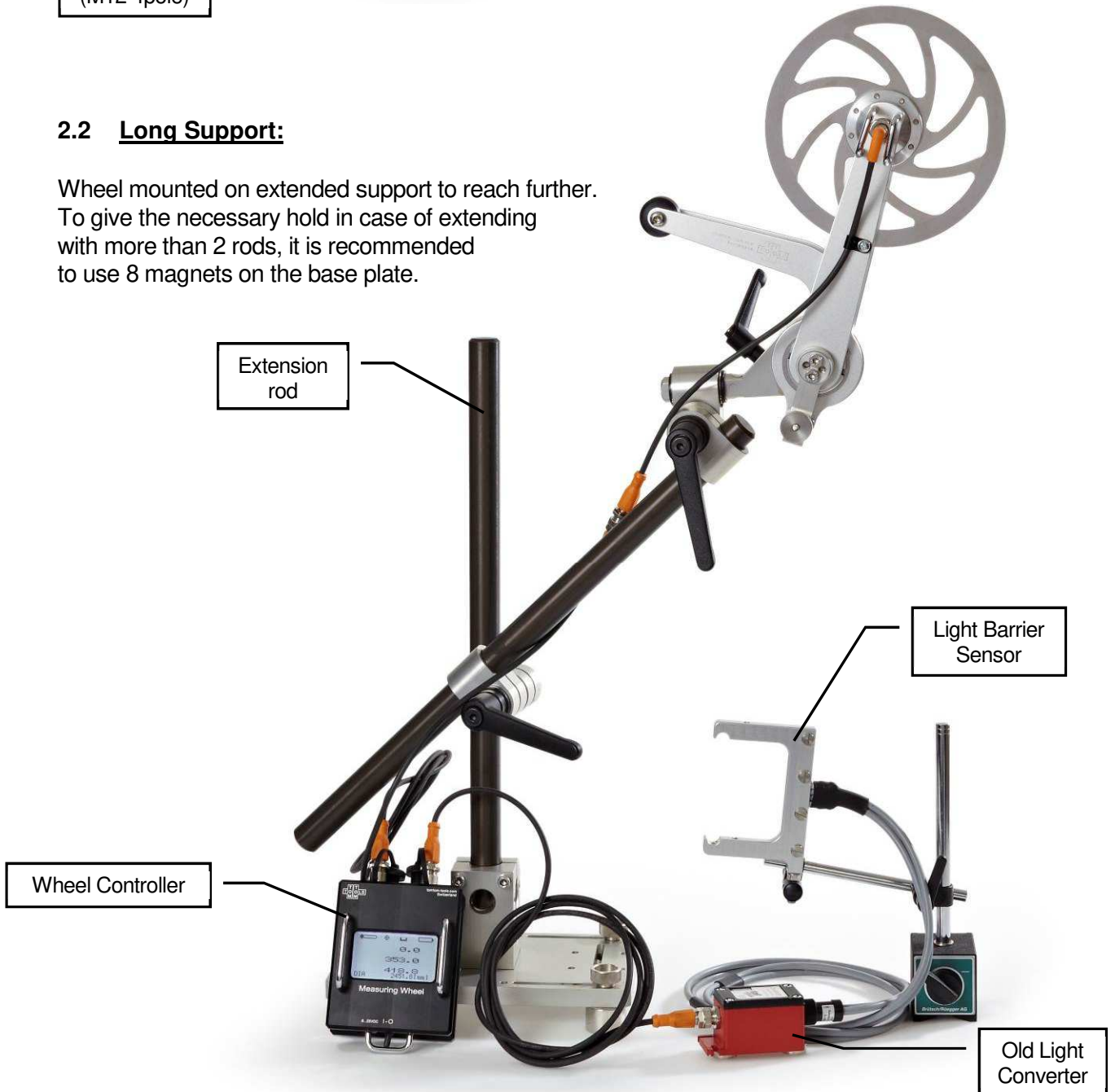
### 2.1 Short Support:

Wheel directly mounted to the base plate



### 2.2 Long Support:

Wheel mounted on extended support to reach further.  
To give the necessary hold in case of extending with more than 2 rods, it is recommended to use 8 magnets on the base plate.

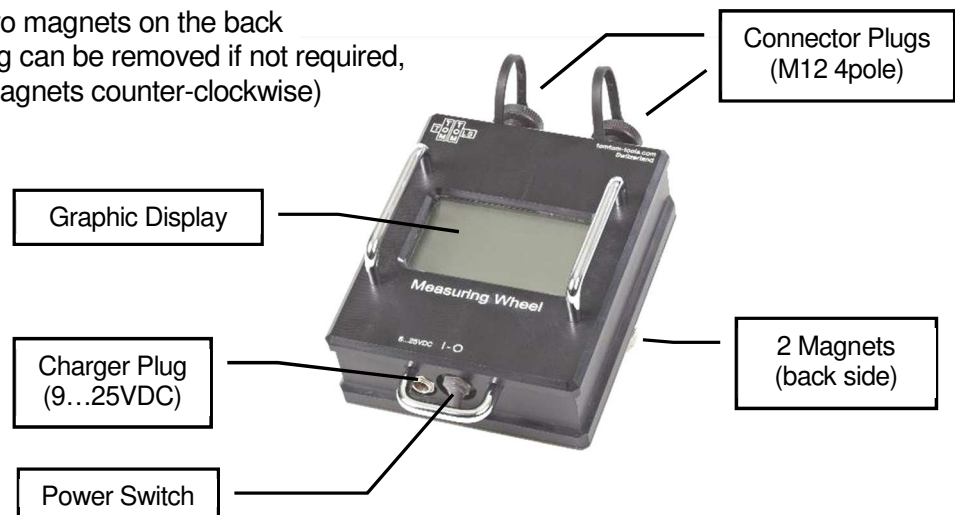


### 2.3 Wheel Controller:

The Wheel Controller supplies the power and processes the acquired values. It consists mainly of the following components:

- **Switch board** with impulse counter, graphical display and battery management.
- **Re-chargeable batteries** 4 pieces, size AA, type NiMH (1.2V, >1900mAh)
- **Tough housing** with two plugs to connect the wheel and the light barrier sensor

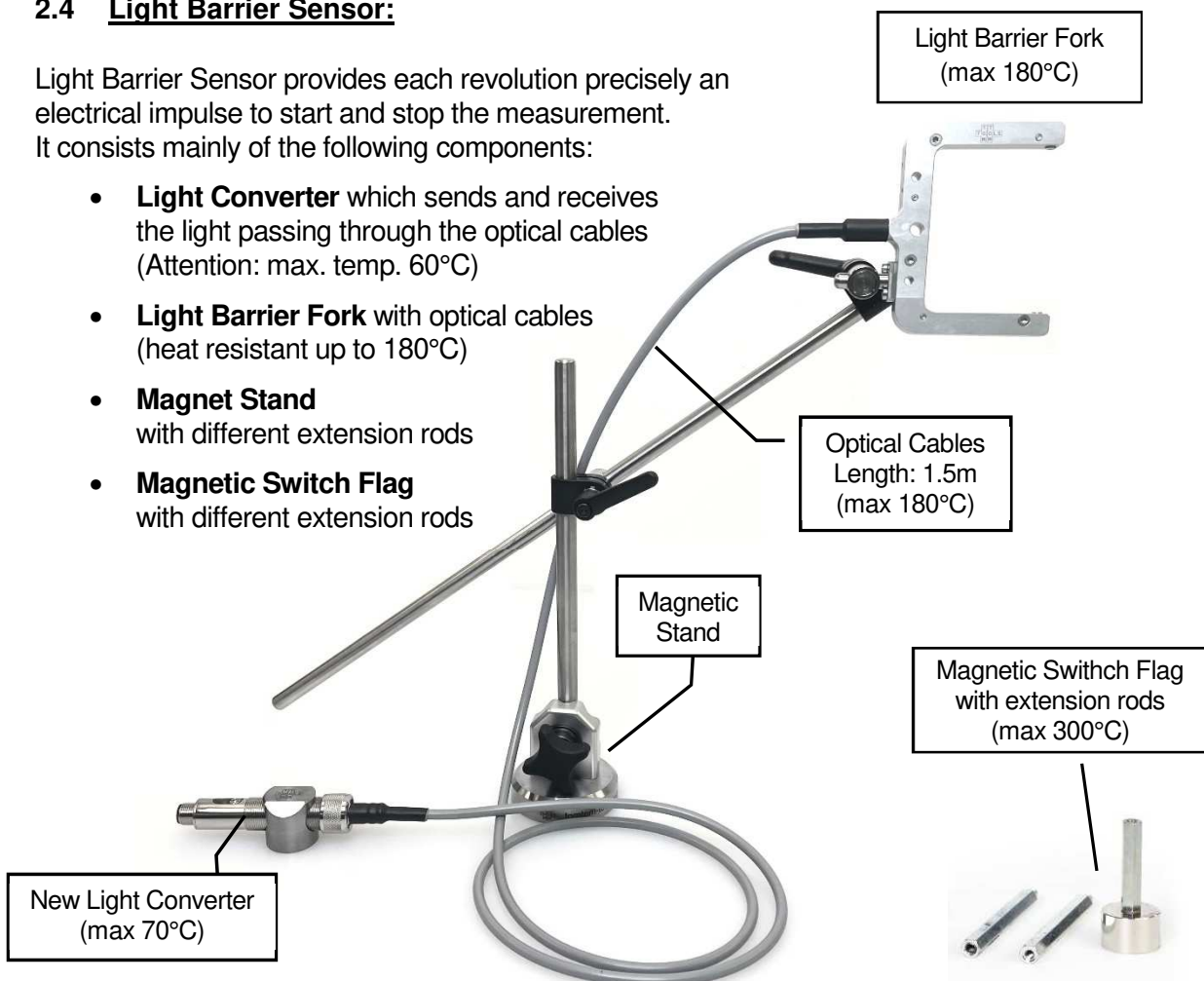
**Note:** The two magnets on the back of the housing can be removed if not required, (by turning magnets counter-clockwise)



### 2.4 Light Barrier Sensor:

Light Barrier Sensor provides each revolution precisely an electrical impulse to start and stop the measurement. It consists mainly of the following components:

- **Light Converter** which sends and receives the light passing through the optical cables (Attention: max. temp. 60°C)
- **Light Barrier Fork** with optical cables (heat resistant up to 180°C)
- **Magnet Stand** with different extension rods
- **Magnetic Switch Flag** with different extension rods



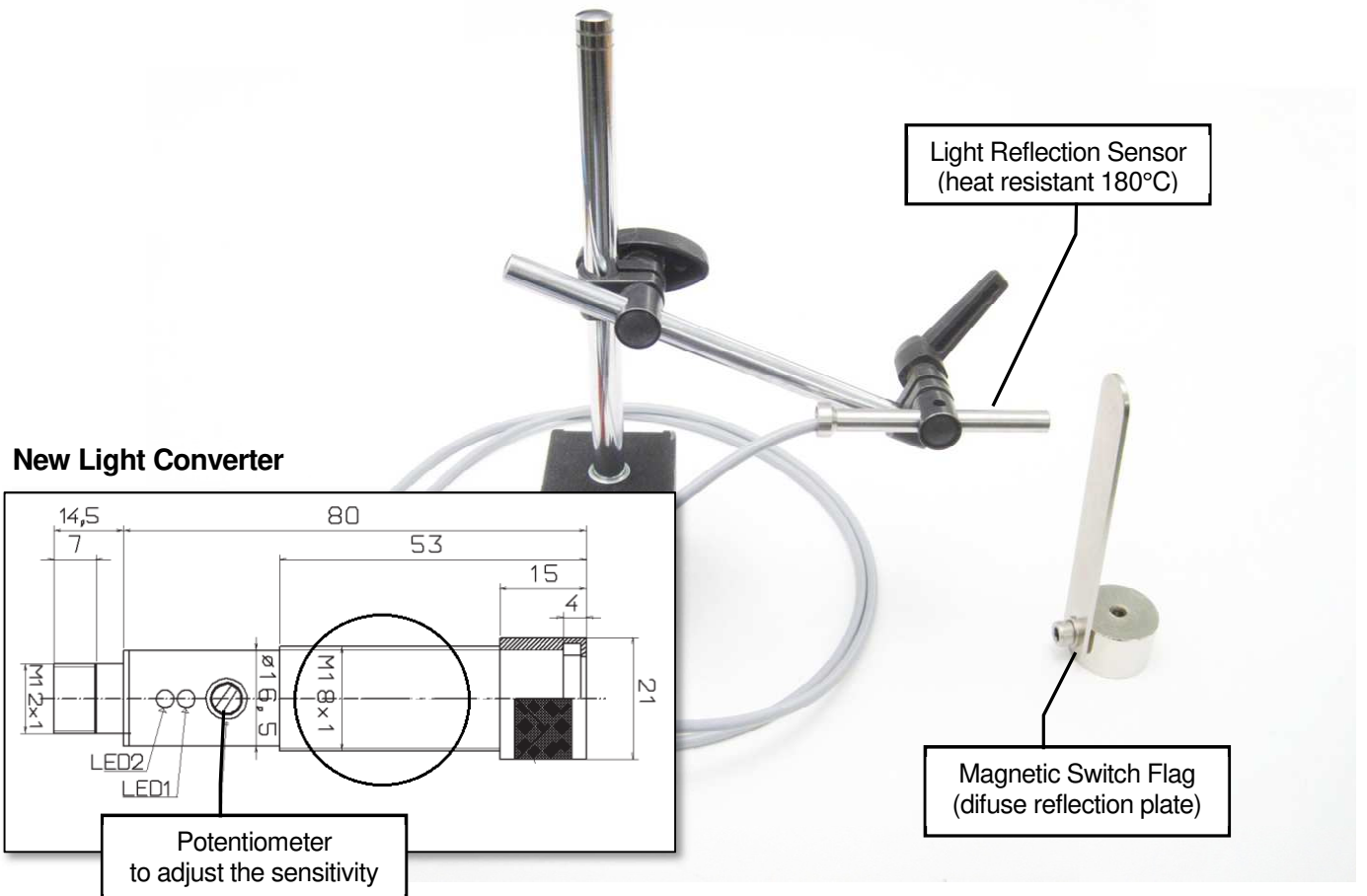
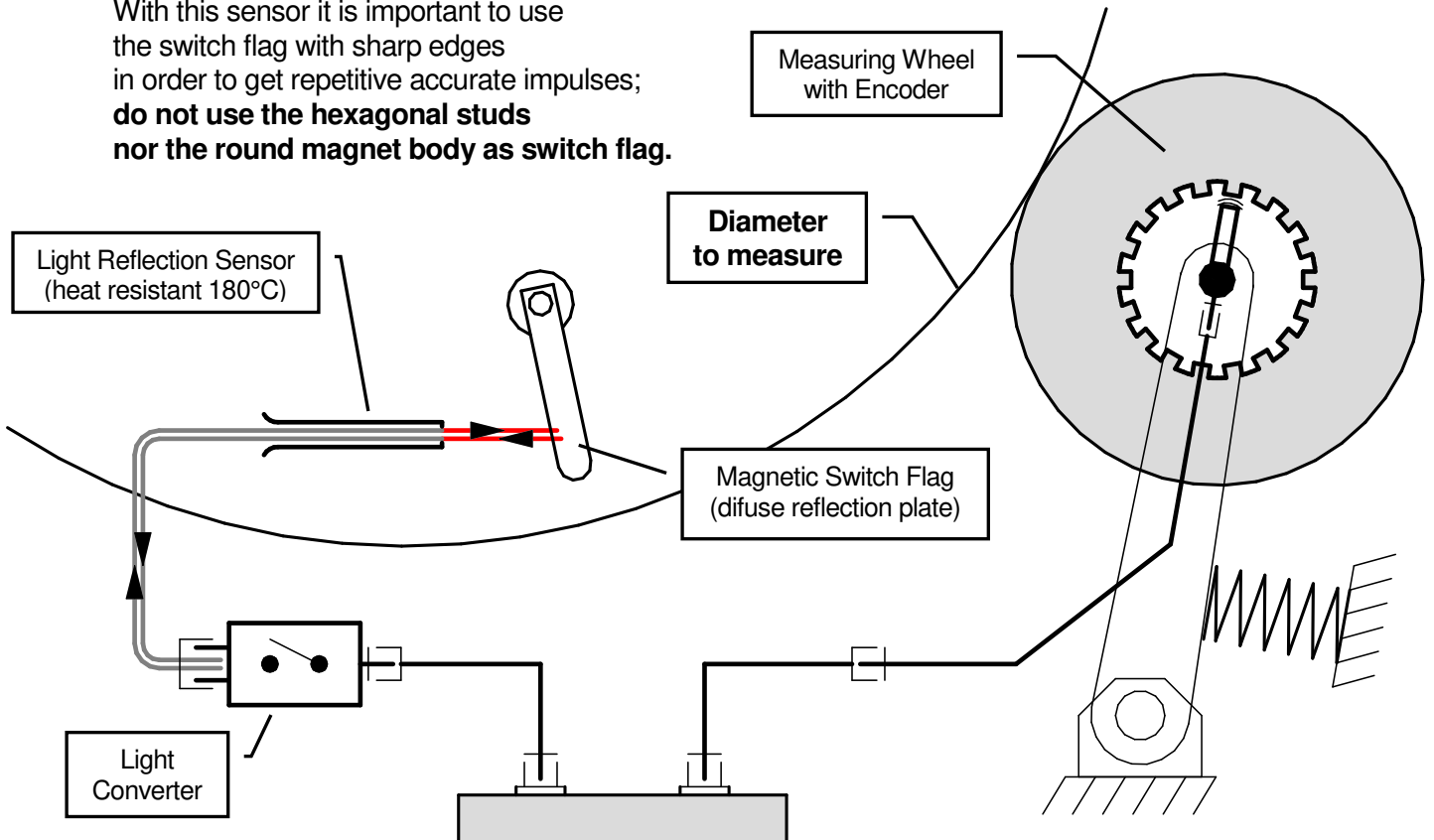


**b) Schematic with Light Reflection Sensor (optional)**

In case of narrow space, it is possible to replace the abovementioned light barrier sensor by this small light sensor, which works by reflection in the range of approximately 10...30mm distance.

**Note:**

With this sensor it is important to use the switch flag with sharp edges in order to get repetitive accurate impulses; **do not use the hexagonal studs nor the round magnet body as switch flag.**



### 3. INSTALLATION OF THE TOOL:

#### 3.1 Place the Light Barrier Sensor

Place the Magnet Stand of the Light Barrier Sensor onto a magnetic surface near the side face of the support roller or tire, which has to be measured. Try to minimize the exposure to heat.

Attach the magnetic switch flag to the side face of the roller or tire. Make sure there is sufficient clearance and the surface does not have thick dust build up to prevent the magnet from falling.

**Special attention has to be given on kiln tires that the switch flag is not interfering with the thrust roller.**

Adjust the Light Barrier Fork in a way that the switch flag is passing through the fork and interrupts the light beam. The light beam is not visible but the two lenses where the light is passing can be found on the two ends of the fork.

The signal is indicated later by a light in the Light Converter and with a symbol in the display of the Wheel Controller.

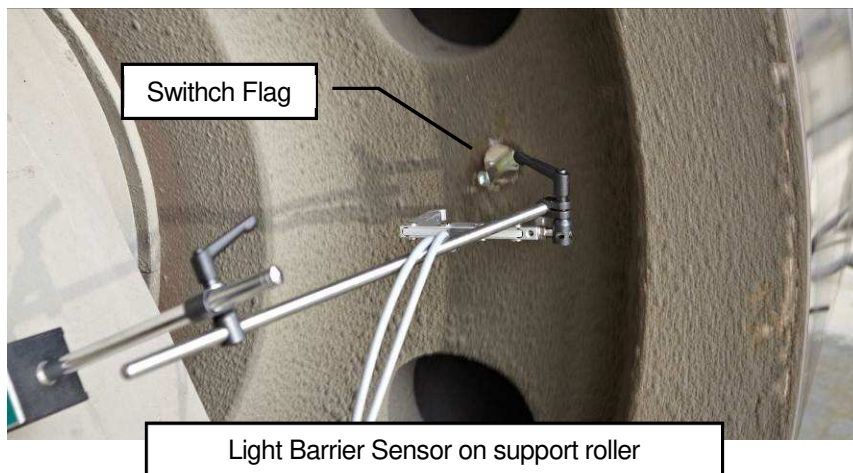


**Caution Hot!**

The tire and afterwards the Switch Flag might be very hot



**Wear Gloves!**



### 3.2 Place the Measuring Wheel

Place the Magnet Stand of the wheel onto a magnetic surface near the support roller or the tire. Assure sufficient cleanliness of the contact surfaces to have sufficient stability. By adding the extension rods, the range can be increased to more than 2m. In this case it is required to attach additional magnets to the baseplate, they can be found in the case under the wheel.

For safety, hold the base plate not directly but on the Extension Rod. To avoid shocks, get first contact with only two magnets as shown in the following picture.



**Caution Clamping!**  
Strong Magnets



Base Plate  
(8 Magnets)

Placing the magnetic Base Plate

Depending on the purpose to measure the roller or tire diameter the wheel can be placed on different positions along the width.

For the purpose of kiln axis alignment or general wear measurement, typically only one reading in the middle is taken.

To get information about the cylindricity various measurements along the width are taken. It provides a clear base for decisions about possible required re-machining of the roller or tire surface.



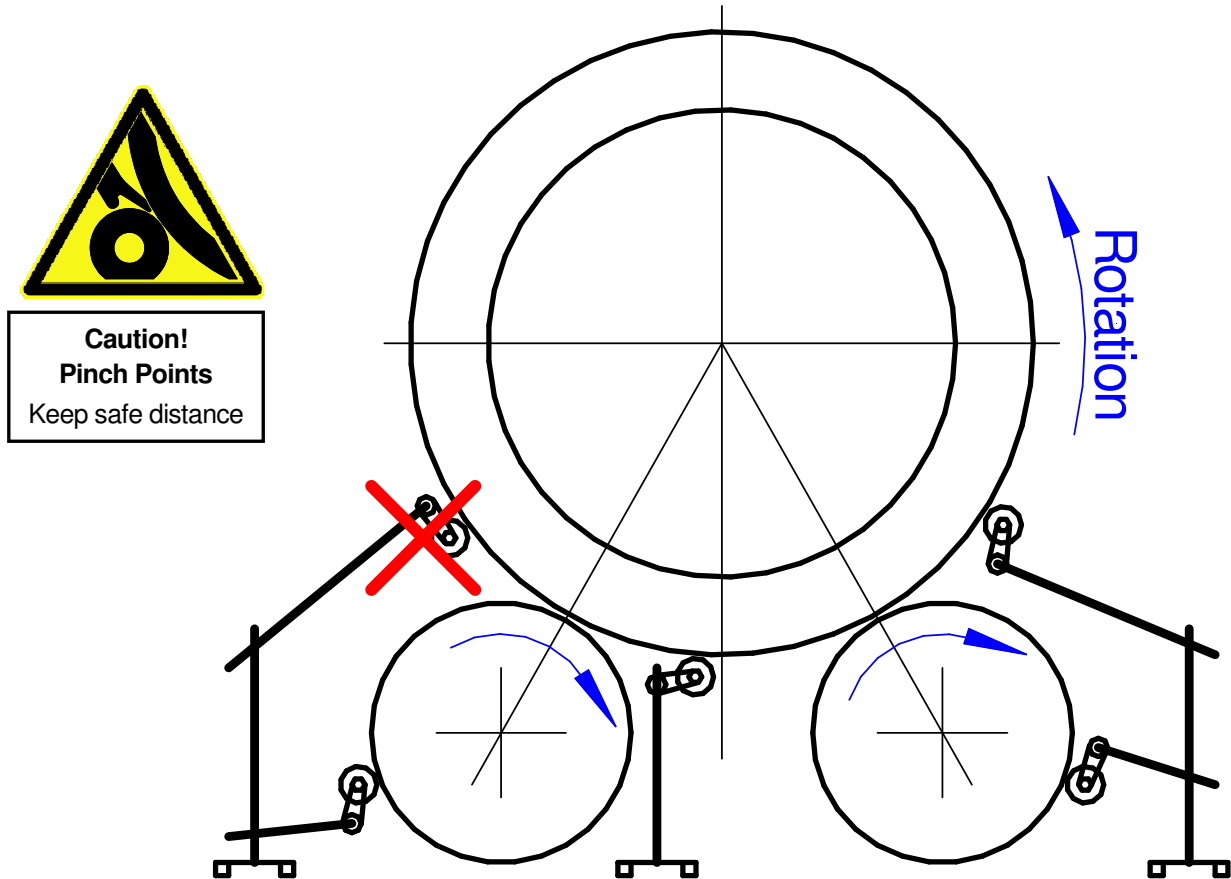
Measure the diameter on different positions

The following sketch provides recommendations for placing the Measuring Wheel.

Place the wheel only in safe areas. Keep distance to the pinch point between support roller and tire.

Never place the Measuring Wheel or the Light Barrier Sensor on the side of the pinch point; place it always on the out running side, to avoid the items get caught between.

Please note also the orientation of the wheel suspension in relation to the sense of rotation.



To avoid slippage it is important that the wheel is adjusted in line with the running surface and some pressure is applied. The pressure can be adjusted by loosening the clamping handle on the hub of the lever arm and pushing the wheel against the surface. Tighten the lever arm again, after adjustment. To fine tune the straightness use the tilt screw as shown in the picture below.



Adjustment of the contact pressure



Adjustment of the straightness

### 3.3 Connect the electrical cables

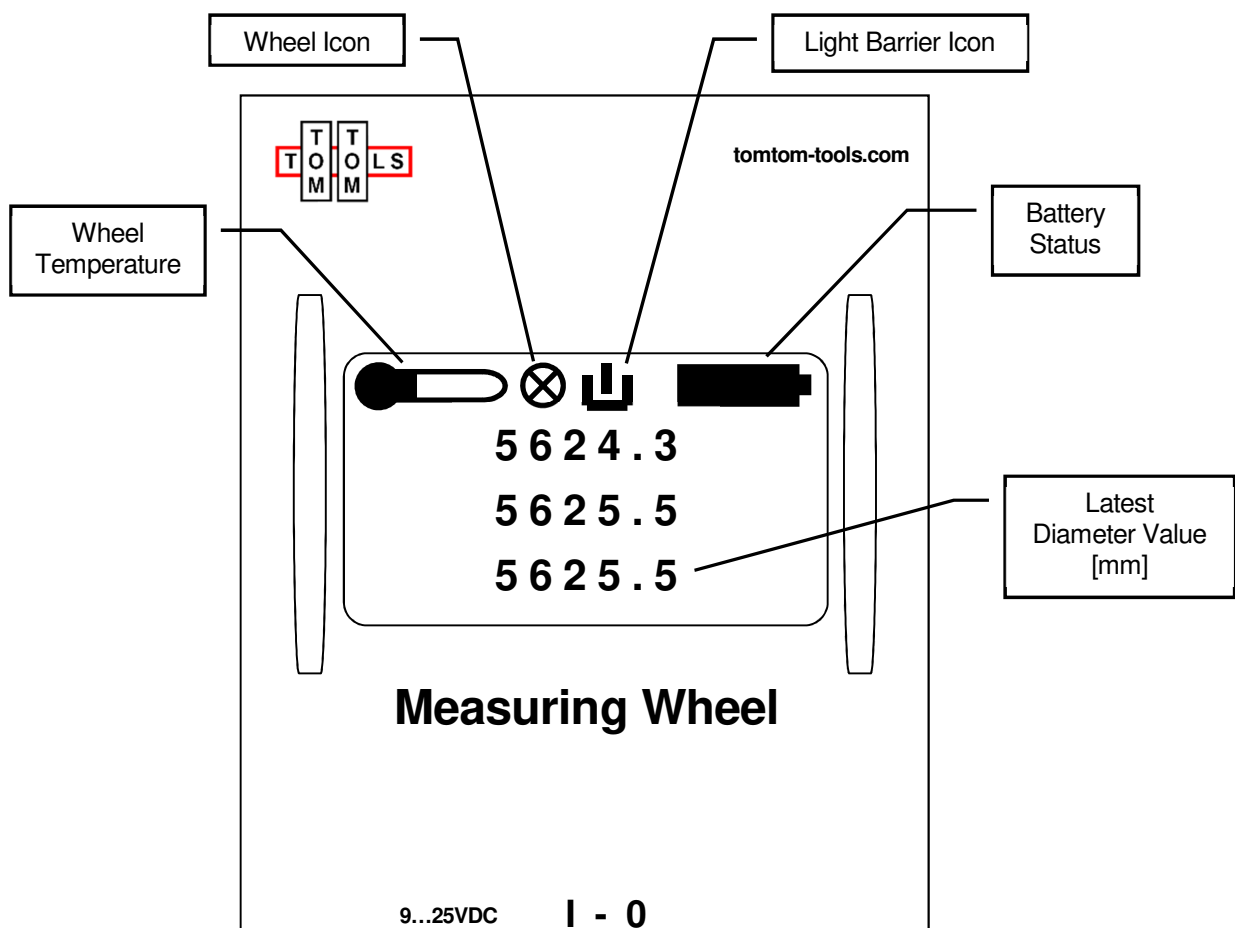
Connect the Measuring Wheel and the Light Barrier Sensor with the two cables to the Wheel Controller. It does not matter, which plug is used for which sensor; the controller is detecting the devices and allocates the signals accordingly.

## 4. TAKE MEASUREMENT

Start the Wheel Controller. As soon the wheel is turning it is recognized by the wheel controller and the icon appears in the display next to the respective plug.

Also the icon for the Light Barrier Sensor appears and indicates when the switch flag passes through. To protect the wheel, its temperature is measured and displayed on the screen. In case of high temperature, an alarm message will appear and the wheel has to be removed from the kiln.

The diameter values are shown in stack mode with three rows. The latest value is displayed in the lowest row and pushes the previous values up. This makes the fine tuning of the wheel easy, where the highest diameter value has to be found; the value with no wheel slippage.



## 5. TRANSFER MEASUREMENT RESULTS TO COMPUTER

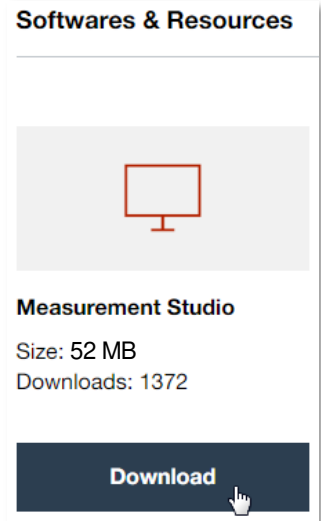
There exists the possibility to transfer the measured values, which are displayed on the Wheel Controller, directly via Bluetooth to a computer (Windows). It makes it very easy to save, visualize and analyze the results.

### 5.1 Software Installation:

The software (**TomTom-Tools Measurement Studio**), which is used for the Measuring Wheel and for all others of our tools, comes along with the tool kit on a USB memory stick. Nevertheless it is recommended to **install the software from [www.tomtom-tools.com](http://www.tomtom-tools.com)**, where always the latest version is available.

During any start of the Measurement Studio, it is checking for updates if the computer is connected to the internet. In case of available upgrades the user gets asked if they should be downloaded and installed.

Please keep your PC up to date.

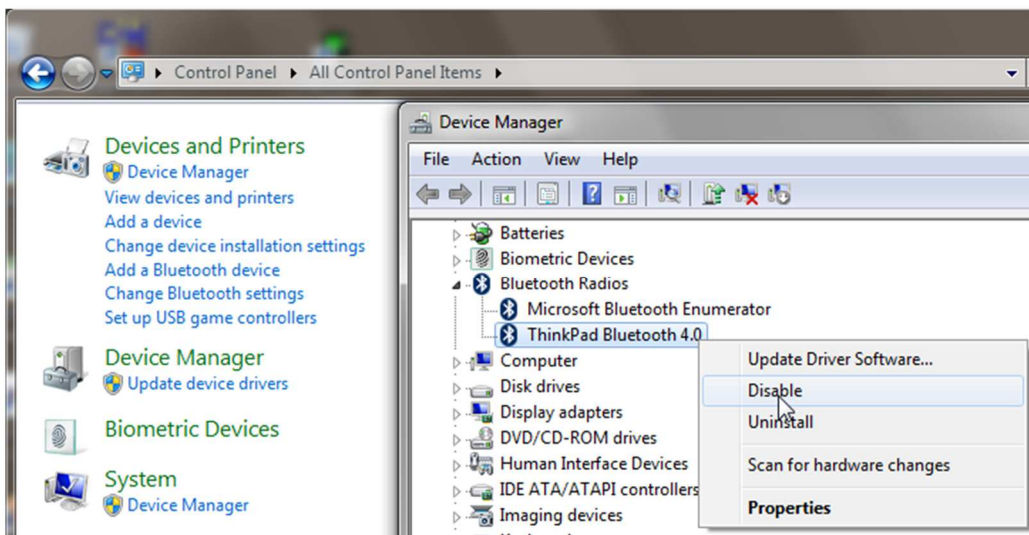


### 5.2 Bluetooth Adapter

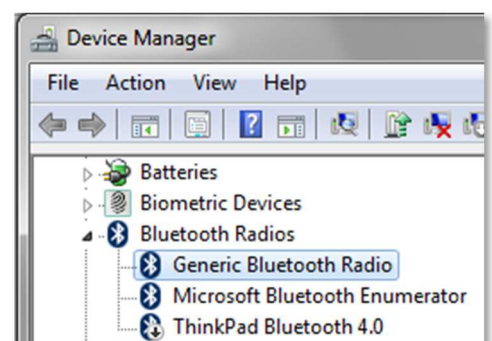
To ensure, the data connection between the Measuring Wheel and the PC is reliable, even in the difficult environment around a rotary kiln, a Long Range Bluetooth adapter (ZEXMTE or Sena Parani UD100) comes along with the tool kit.

**Note:**

- The TomTom-Tools are designed to communicate **only with the generic Windows Bluetooth Stack**. If there is another Bluetooth software installed (e.g. Toshiba, Widcomm, Intel, ThinkPad,...), **deactivate it in the Device Manager** as shown below:



- Then plug the Bluetooth adapter UD100. Windows will recognize the new hardware and automatically install the suitable Windows driver (Windows generic Bluetooth)
- The Device Manager will show the following:
  - Generic Bluetooth Radio
  - Microsoft Bluetooth Enumerator
  - the not required Bluetooth is down (indicated by the small arrow at the Bluetooth icon)



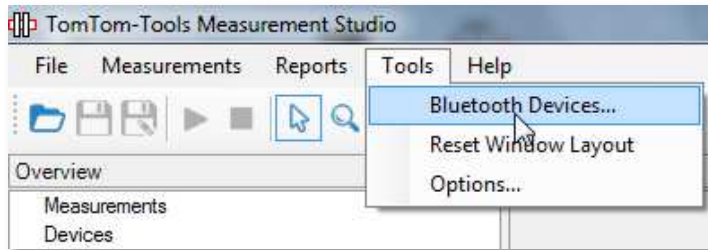
### 5.3 Connect the Device with the Laptop

After the software installation is completed, switch the Wheel Controller on.

A new tool has to be added (paired) to the computer the first time only.

To add the tool, click on **[Tools / Bluetooth Devices...]**

Fig. 5.3.1



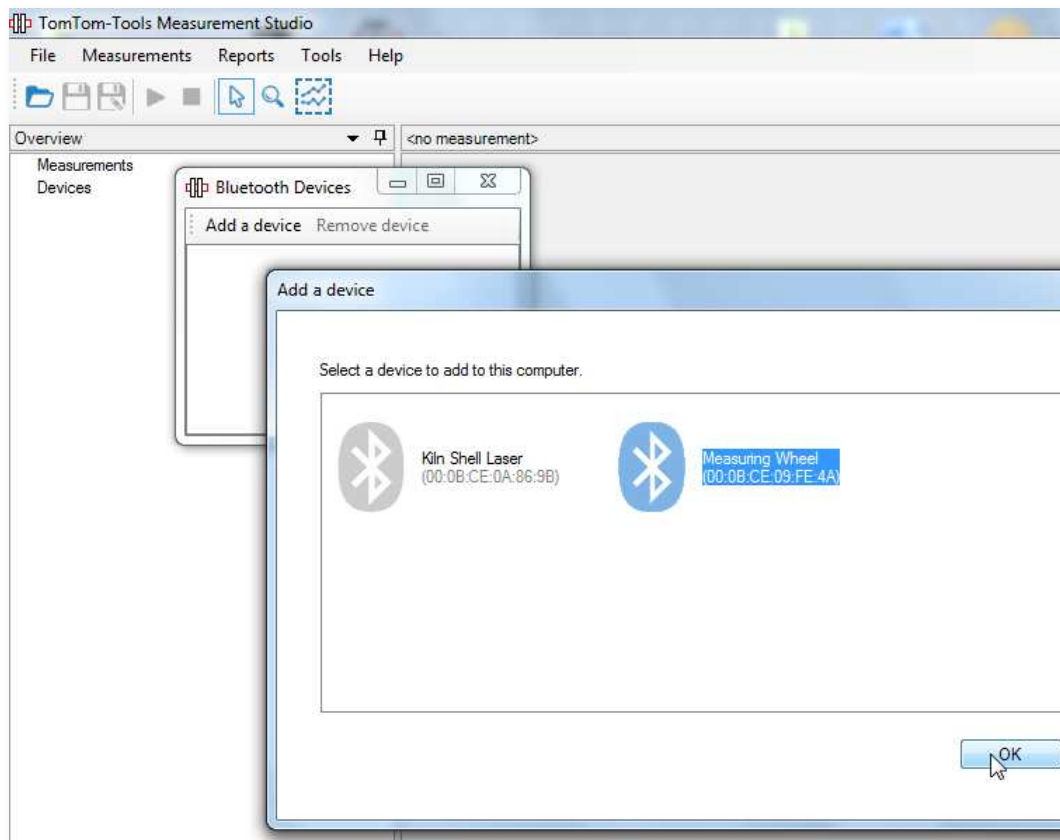
By clicking on “Add a device”, the PC will search for devices. The new devices will be displayed in a window, where they can be selected (in this case the Measuring Wheel).

Add it by clicking on **[OK]**.

**Note:** Depending on the search speed of the computer, it might take up to one minute.

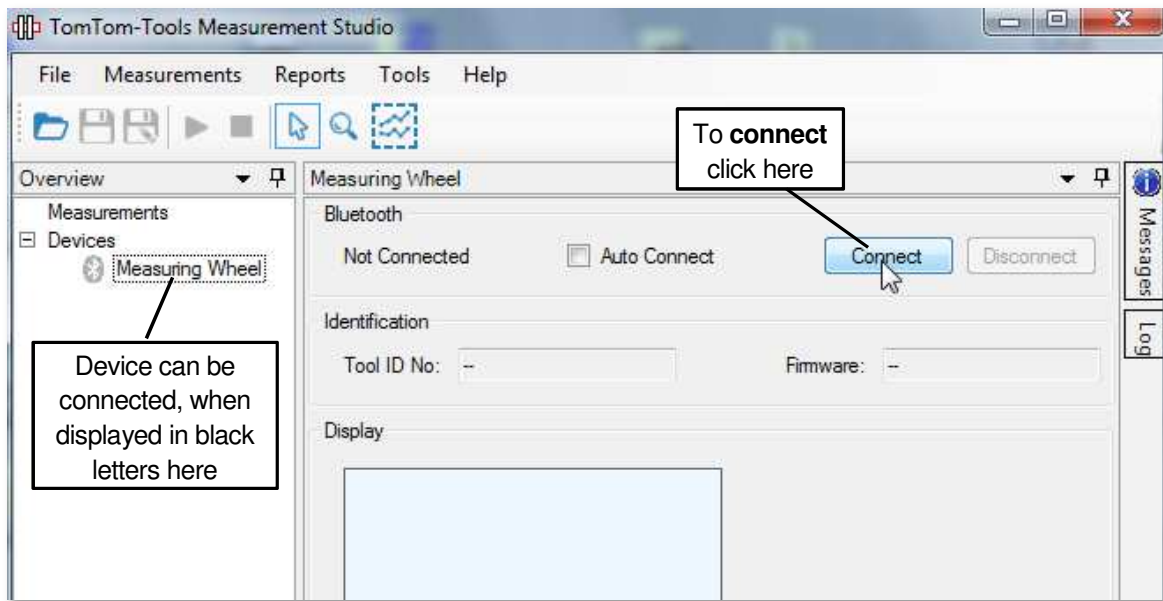
To remove a device, click on **[Remove device]**.

Fig. 5.3.2



All devices, which were added (paired) once, will appear in the device window at the left side in the Measurement Studio. As soon as the devices are switched on and in range, they will appear in black letters and are ready to be connected. To connect a device, click on the **[Connect]** button. For connecting automatically, enable the check box **[Auto Connect]**

Fig. 5.3.3 (Device Window)

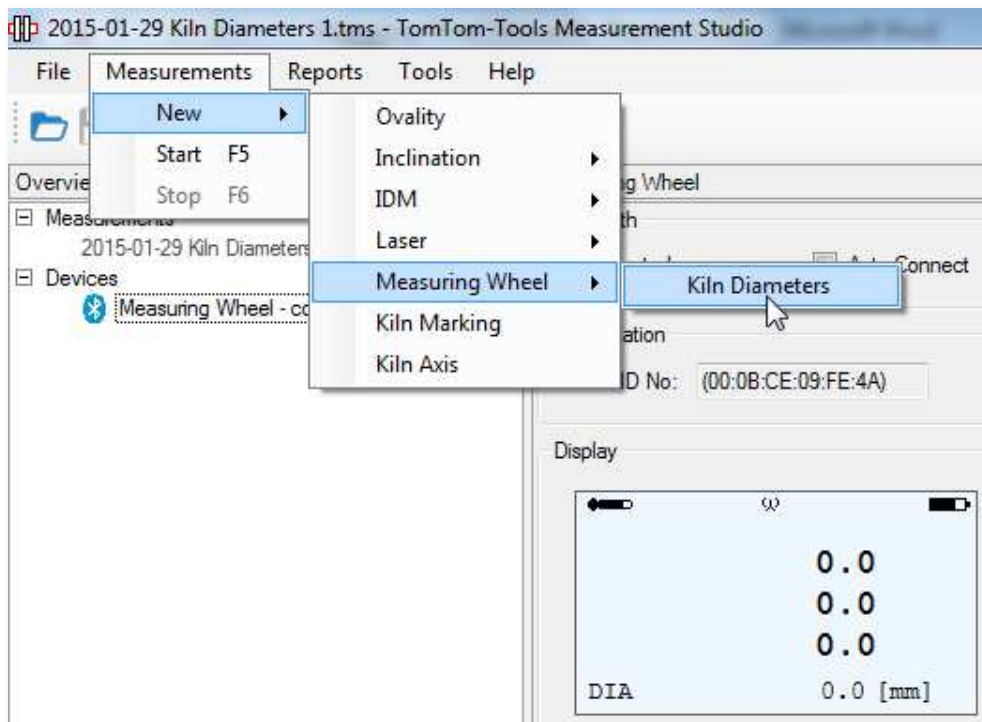


## 6. TAKE MEASUREMENTS WITH COMPUTER

### 6.1 Set Up the Measurement Window

- To set up a new measurement, click on:  
**[Measurement / New / Measuring Wheel / Kiln Diameter]**

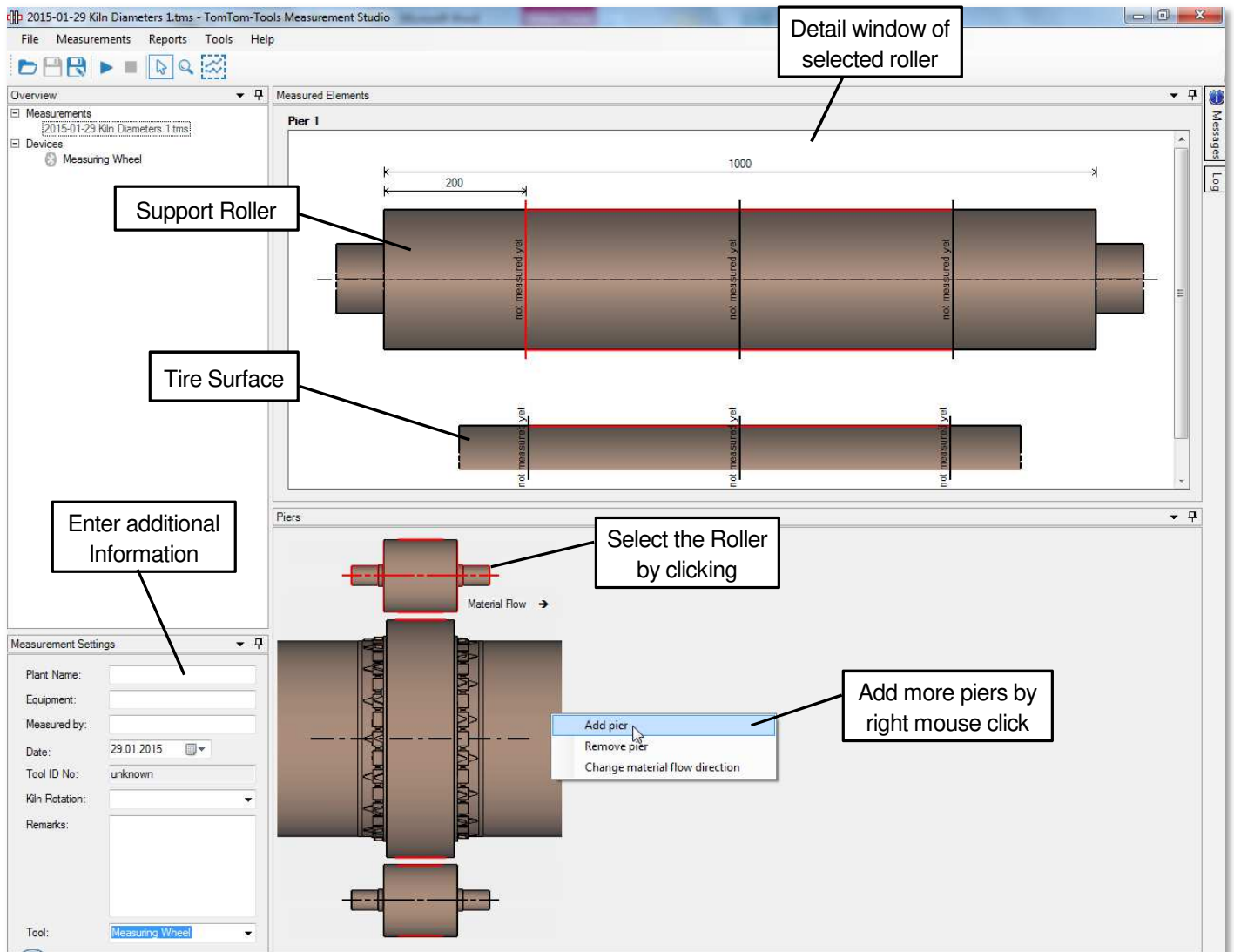
Fig. 6.1.1



- The first pier will be displayed as per default
- More piers can be added by the right mouse click “**Add pier**” as shown in Fig. 6.1.2
- Put some additional useful information about the measurement into the “Settings Window”
- Specify if the “Material Flow direction” by right mouse click

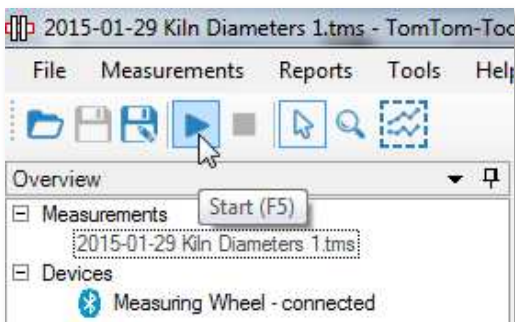


Fig. 6.1.2



## 6.2 Start Measurements

- To start a new measurement, click on the **Start Button** or press **F5**



The values will appear in the graph and the red line indicates the shape of the outer surface of rollers and tire.

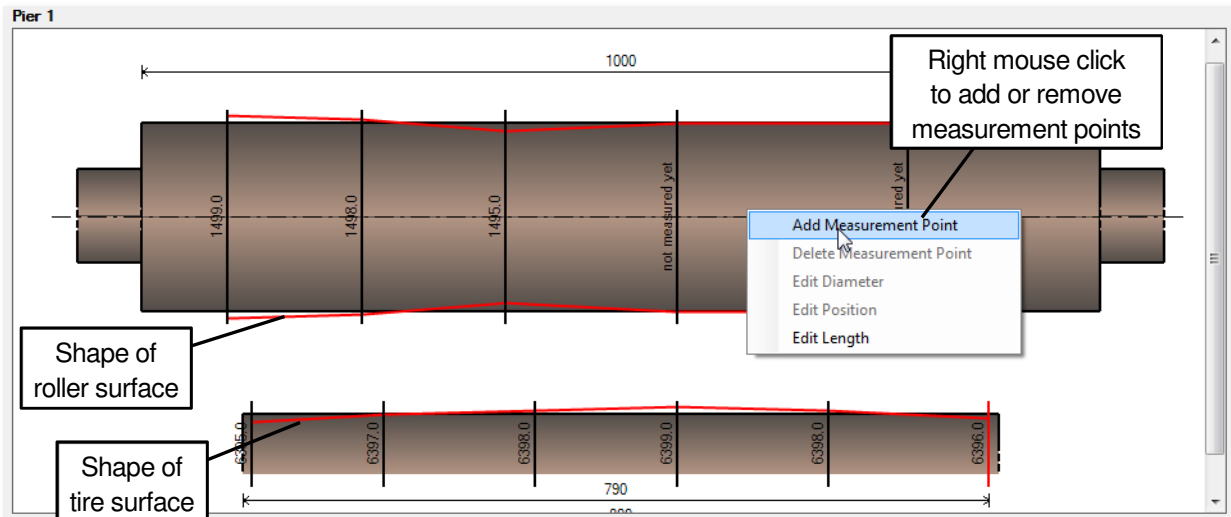
- To stop the measurement, click on the **Stop Button** or press **F6**  
With that, the last value will remain in on the screen

**Note:**

For a long lifetime of rollers and tires on a rotary kiln, it is essential to have a good contact. The target is to have cylindrical surfaces. However slight deviation can often be found, which are not necessarily always harmful. The impact on the surfaces, which are rolling on each other, is mainly defined by the fact how good they fit together. Therefore this software module was developed; to visualize how the surfaces are matching.

To get more detailed information about the cylindricity, add measurement points by right mouse click. To move the position of the measurement point, drag them to the right position with the mouse or enter the value manually.

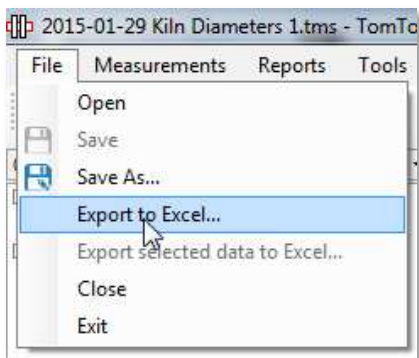
Fig. 6.2.2



**6.3 Export to Excel**

All data can easily be exported to excel.

Fig.6.3.1



**6.4 Create a report**

The measurements can be extracted into a report. All additional information from "Setting Window" is included in the report as well.

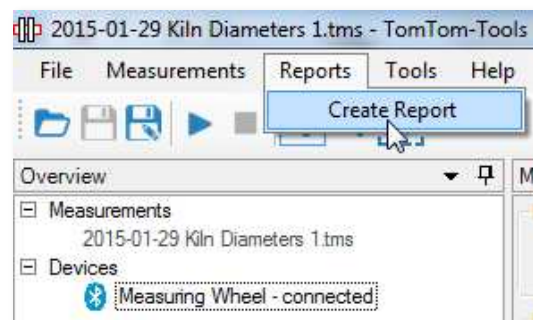
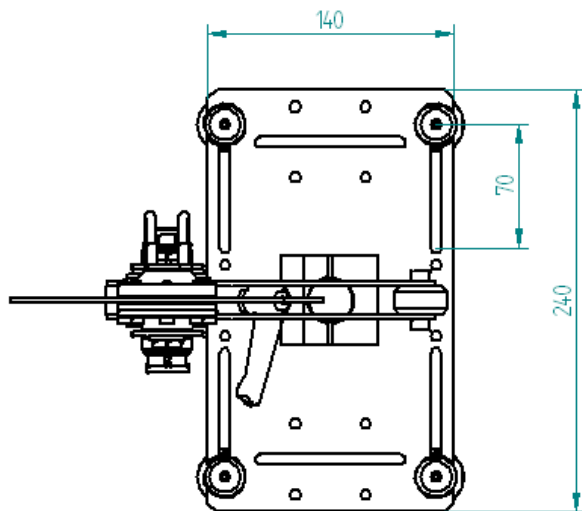
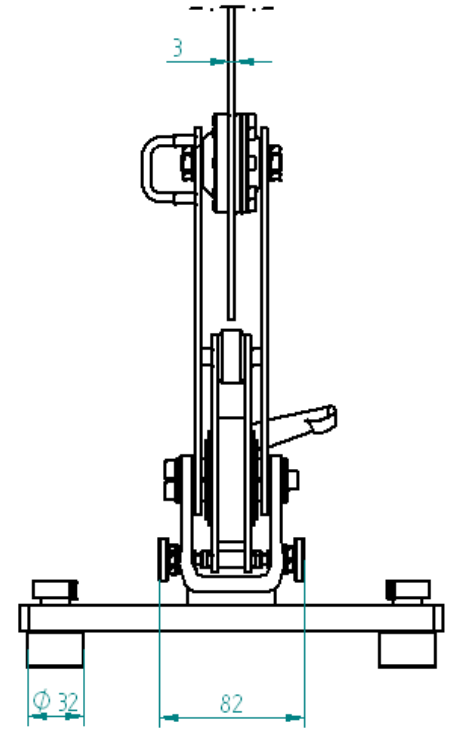
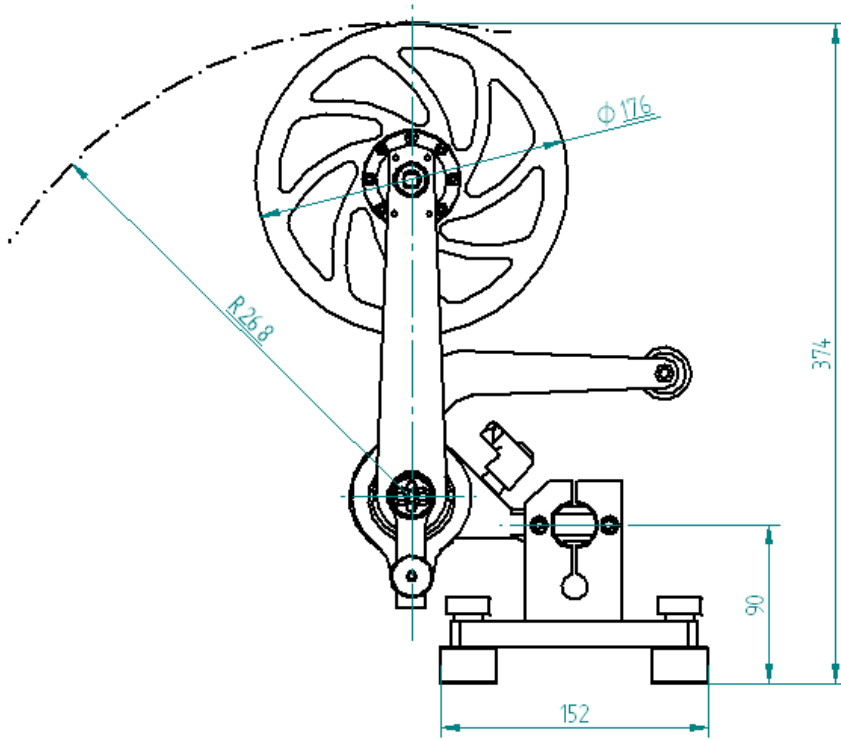


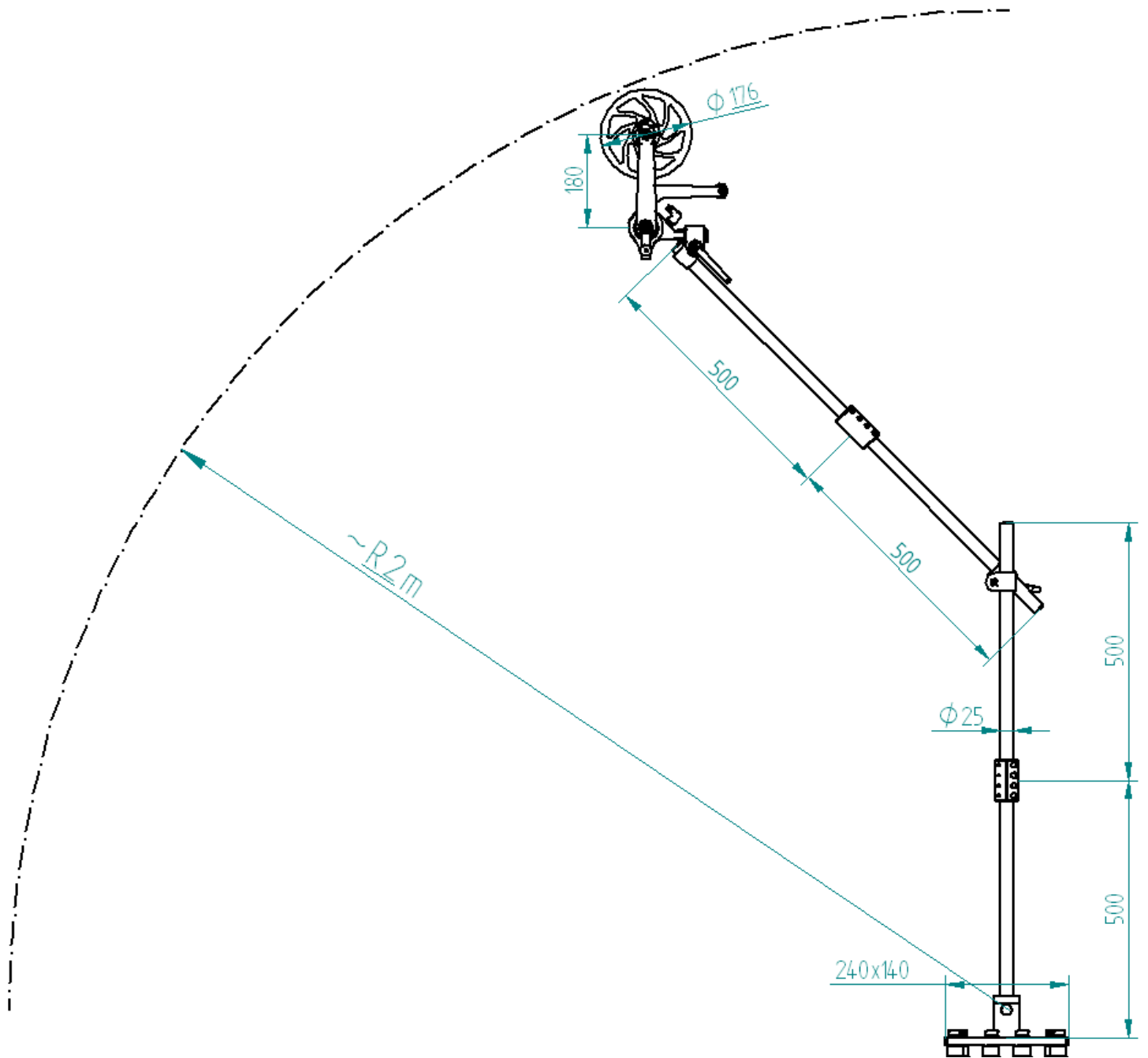
Fig. 6.4.1

7. **MAIN DIMENSIONS**

7.1 **Short Support**



7.2 Long Support



**TomTom-Tools GmbH** Switzerland

[www.tomtom-tools.com](http://www.tomtom-tools.com) [info@tomtom-tootools.com](mailto:info@tomtom-tootools.com)